

TEKLA BASECAMP

AUG. 27 - 29

2
0
1
9

What's New for Modeling



WELCOME TO BASECAMP 2019!



Ryan Page

Concrete Application Specialist

Tekla Structures



Tekla Structures: What's New

Agenda

- Changes in Installation for 2019
- Recent Improvements to the User Interface
- Updates to Model Sharing
- Updates to Concrete Modeling and Reinforcement
- Highlights in Formwork Improvements
- Highlights in Components
- Updates to CMU Tools
- Improvements to Drawings
- Interoperability Improvements

What's New for Modeling

CHANGES TO INSTALLATION FOR 2019



Changes to Installation: Environment Folder Structure

- The Environment Folder Structure has been reorganized.
 - Easier to keep folder content up to date.
- Folders are logically based on roles or materials
 - **\Concrete**, **\Precast**, **\Engineering**, etc.
- The **\General** folder contains content common to all roles.
- Added New Environment: **Canada**

Changes to Installation: Updates and Additions to Roles

- There is now only one US environment.
 - You can switch between imperial and metric modeling by using roles.

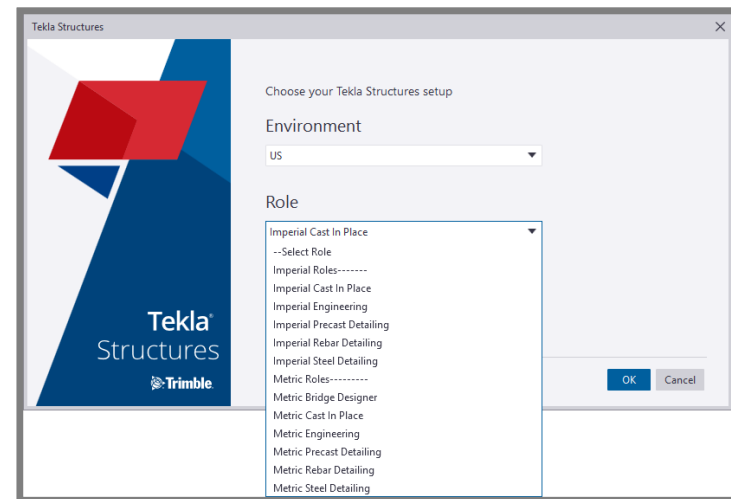

- Added Bridge Designer Role (US Metric)
 - Brings Bridge Creator Tab on the ribbon.
 - Tools for Beam Extruder, Concrete Bridge Reinforcement
 - Compliments Bridge Creator Extension introduced in 2018

What's New for Modeling

IMPROVEMENTS TO THE USER INTERFACE



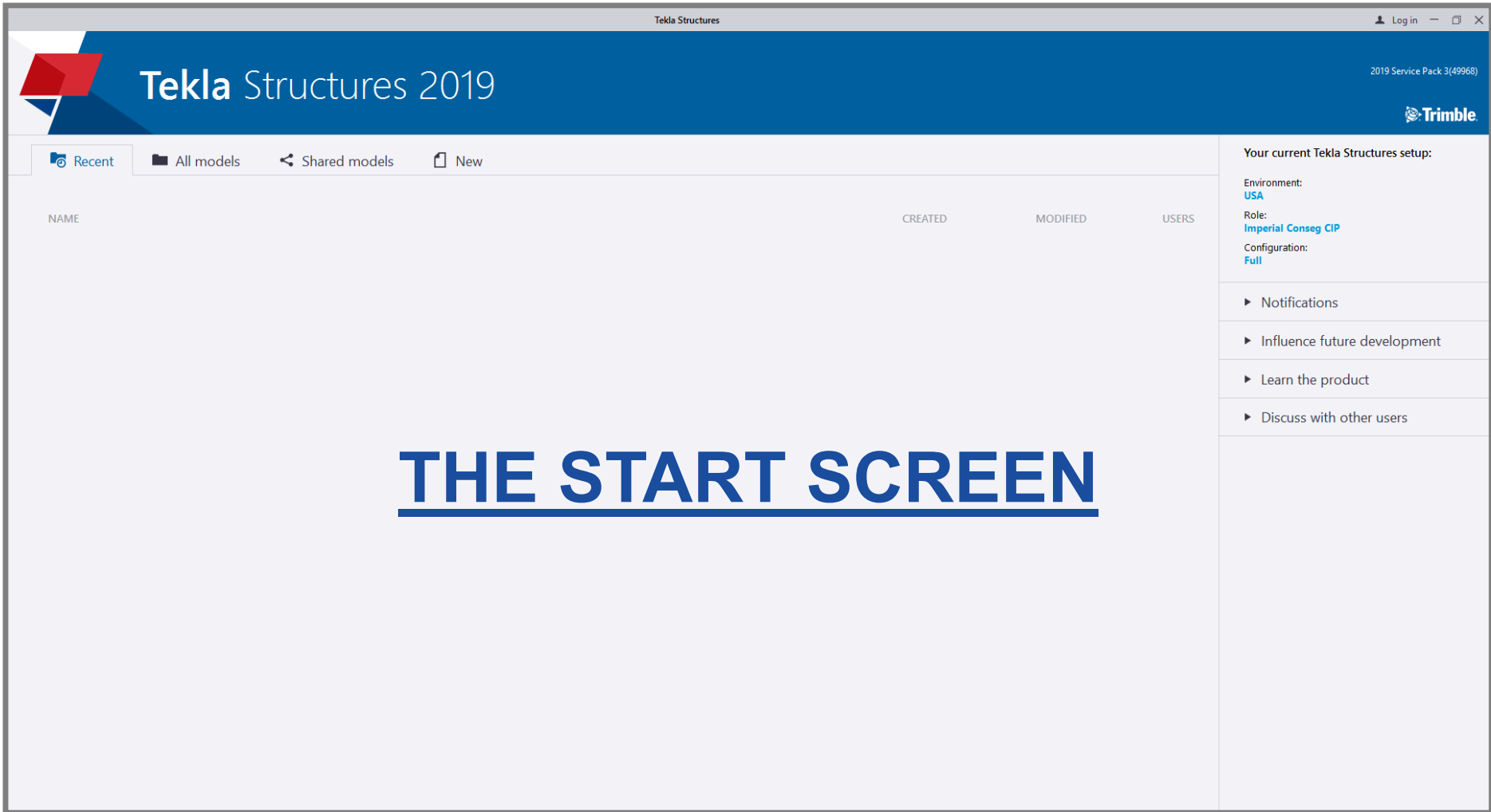

User Interface: Start Screen

- Date Created and Modified now have time stamps.
- Added Shared Models tab
- Can convert models to single or multiuser using new drop down next to **OPEN**.
- Can now manage models
 - Right click a model
 - Delete the Selected Item
 - Clear All
 - Clear Invalid Entries

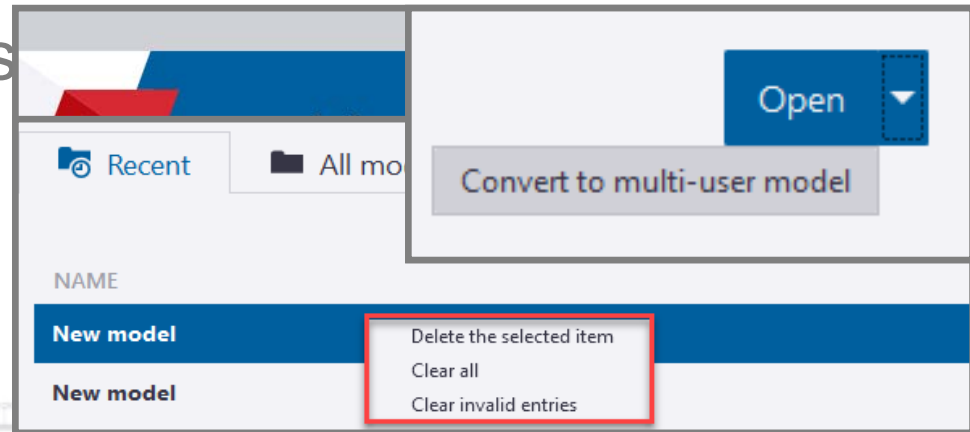

User Interface: Part Labels

- New Part Label Options
 - All
 - Selected
 - **Main Part for Selected**
 - **Main Part for All**
 - The Part Label check box is now automatically selected when you click **Add>** to add a property.

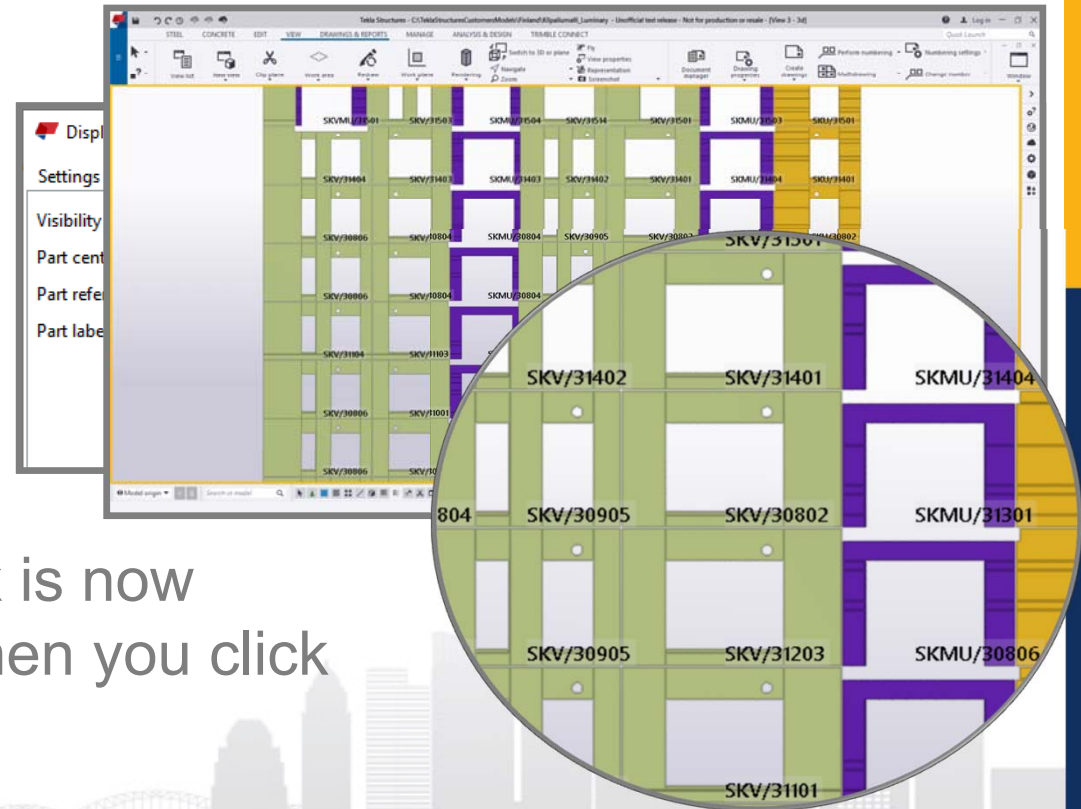

GRID IMPROVEMENTS



User Interface: Grid Improvements

- Properties of all grids and single grid lines now accessed through the Properties Pane.
- Create native Radial Grids in 2019
 - Can be insert by picking a point or defining origin in the Properties Panel.
 - Radial Grids can be edited with Direct Modification and the Contextual Toolbar.
 - Independent options for view creation in the **New View – Creation of Views Along Grid Lines** dialog.

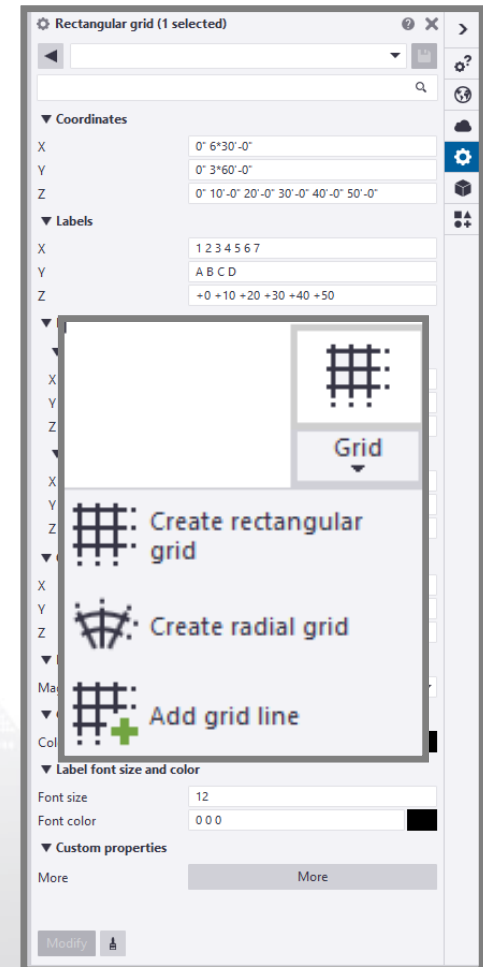

User Interface: Radial Grids



User Interface: Construction Objects

- Introduction of Curved Construction Objects
 - Construction Polycurve
 - Construction Arc
- New: Copy with Offset
 - For Construction Objects
 - Increased ease use when placing Construction Objects for layout or reference.

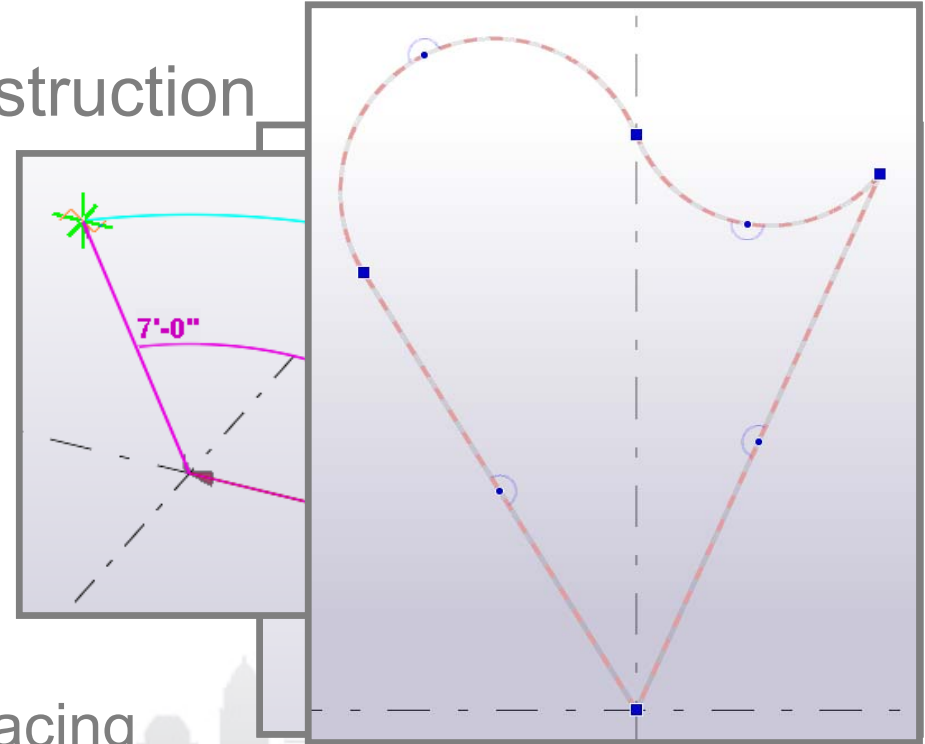

User Interface: Construction Objects

- Can now change a construction line to an arc.
 - Requires Direct Modification
- Construction Circle is now two methods of input:
 - Using a center point and radius
 - Using three points
- **NEW:** Construction Object Line Types
 - Can change line type in the Properties Pane.

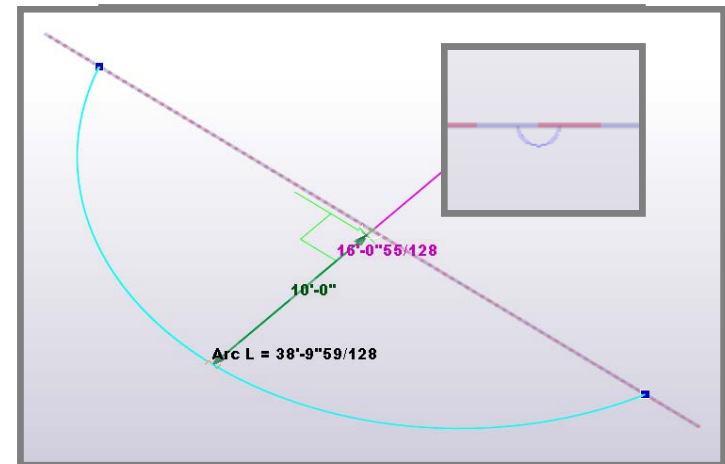

User Interface: Ortho Snapping

- Improved Ortho Snapping
 - Previously would remember last picked point as a reference point.
 - Now when a command is interrupted the reference point is cleared.
 - Results in more accurate snapping.
 - Eliminates unwanted results such as part being creating in unexpected planes.

User Interface: Other Improvements

- Delete all Clip Planes with a Single Command.
- View Windows now in alphabetical order.
- Introduced **Select by Identifier**
 - Can easily locate and select objects using the GUID, ID of an object, or the IFC GUID.
 - Works in both modeling and drawing modes.

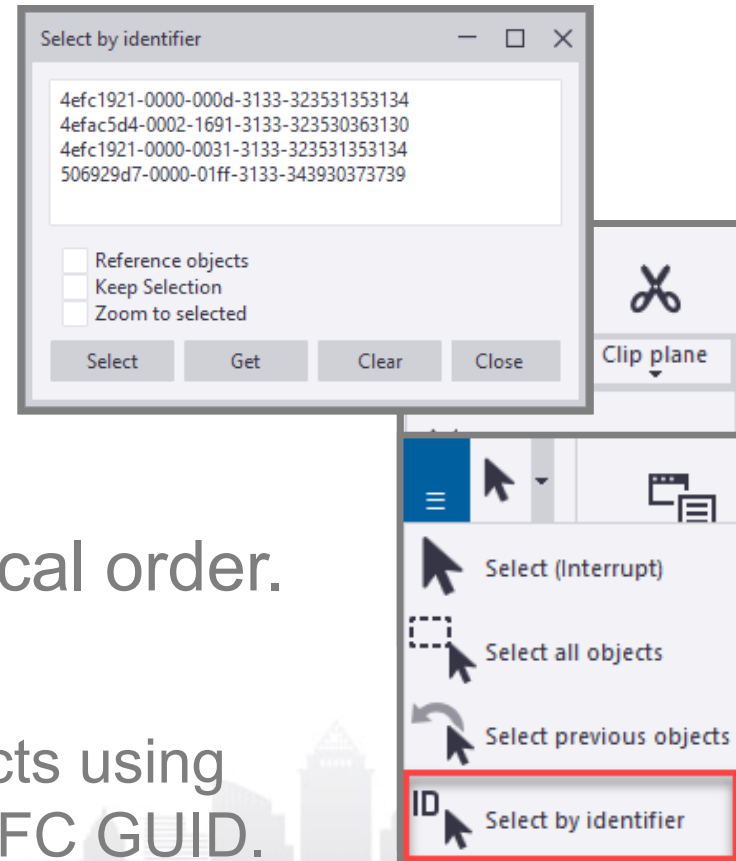

User Interface: Summary

- Updates to the Start Screen make it easier to manage models.
- The addition of native Radial Grids allows for better layout and more control over round structures.
- Improvements to tools to provide more efficient and time savings during model creation and planning.

What's New for Modeling

UPDATES TO MODEL SHARING



Model Sharing: Handling of Parametric Profiles and Conflicting Modifications

- Improvements to Parametric profiles in shared models.
 - Unrecognized profiles are no longer shown as sticks or incorrectly when reading in.
 - Eliminates the need to restart Tekla to correct or import profiles.
 - Provides a faster and more efficient workflow.
- Conflicting Modifications have been improved.
 - Modifications of part cuts, site bolts, added parts, edge chamfers, welds, and sub-assemblies are now removed when reading in.

Model Sharing: Improved sharing operations with reference models

- Reference model object inquiries during read in and write out have been optimized.
 - Speeds up the read in and write out operations especially when there are a large number of reference model objects in the shared model.
 - In the **Changes list** , the names of new reference model objects are no longer displayed.

Model Sharing: Version Control for Drawings

- Changes in Tekla drawings are now managed with **drawing version control**.
 - When a user makes changes to a drawing and shares the changes (using write in model sharing), a new drawing version is generated.
 - Having the version control, unintentional changes to drawings by another user can be identified and version with correct content can be returned to the shared model.

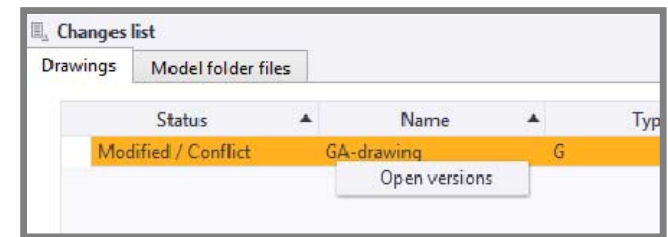

Model Sharing: Scalability and Connectivity

- Next generation sharing service (v.2.0)
 - Updated to current versions of Azure Services.
 - Provides a solid growth path for the expanding use of model sharing.
- Simplified network settings for 2019 and onward.
 - Now only uses TCP port 443, which is open by default.
 - Previous versions will still need to configure TCP 9350-9354.

What's New for Modeling

UPDATES TO CONCRETE MODELING AND REINFORCEMENT



Concrete and Reinforcement: Add & Remove Pour Unit Content

- Added additional commands for adding and removing parts from Pour Units.



Concrete and Reinforcement: Add & Remove Pour Unit Content

- **Add to Pour Unit** and **Remove from Pour Unit** now available via the contextual menu.

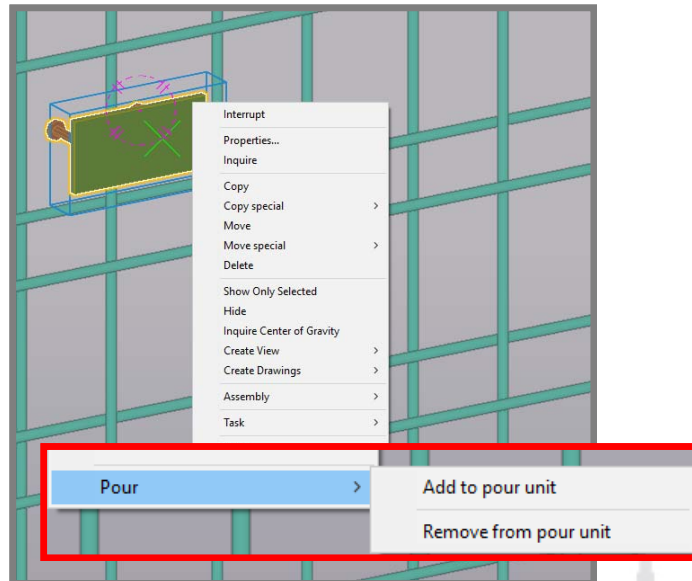

- Additional commands can be found via **Quick Launch**.
 - Can be mapped to keyboard shortcuts.
 - Allows for easier and more effective control objects within pour units.

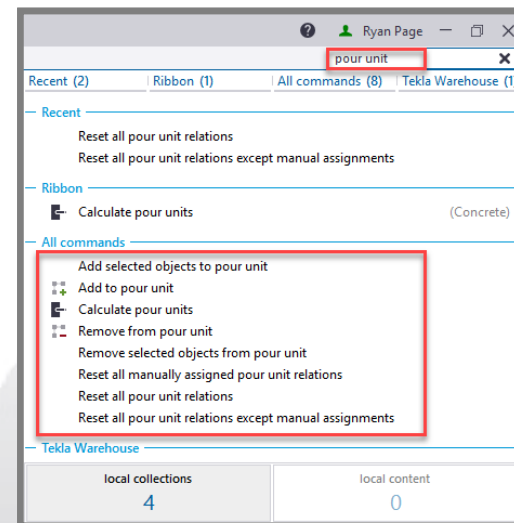

Concrete and Reinforcement: Updates to Rebar Set Modifiers

- Control visibility of Rebar Set Modifiers with new drop down on the Concrete tab.
 - Quickly modifies the associated Advanced Options directly.
 - Allows for less cluttered visibility when using rebar sets.
 - Improve efficiency in selecting modifiers for modification.

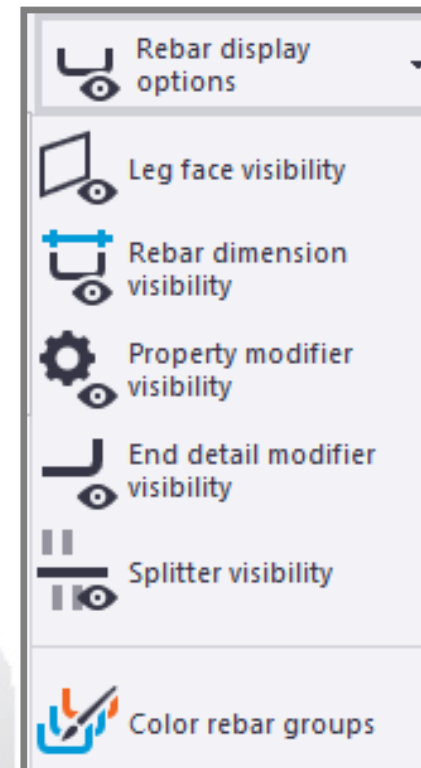

Concrete and Reinforcement: Rebar Set Distribution

- Control the distribution of Crossing Bars during creation.
 - Execute right from the contextual toolbar.
 - Provides greater control in rebar detailing.
 - Shorten or lengthen using end handles with direct modification.

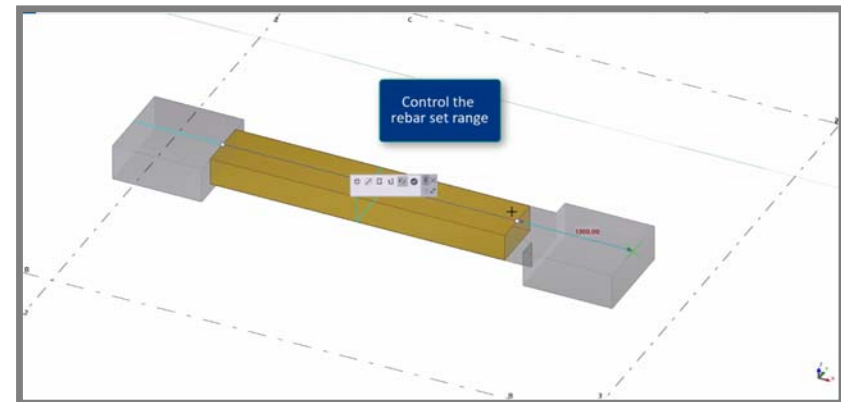

Concrete and Reinforcement: Rebar Sets

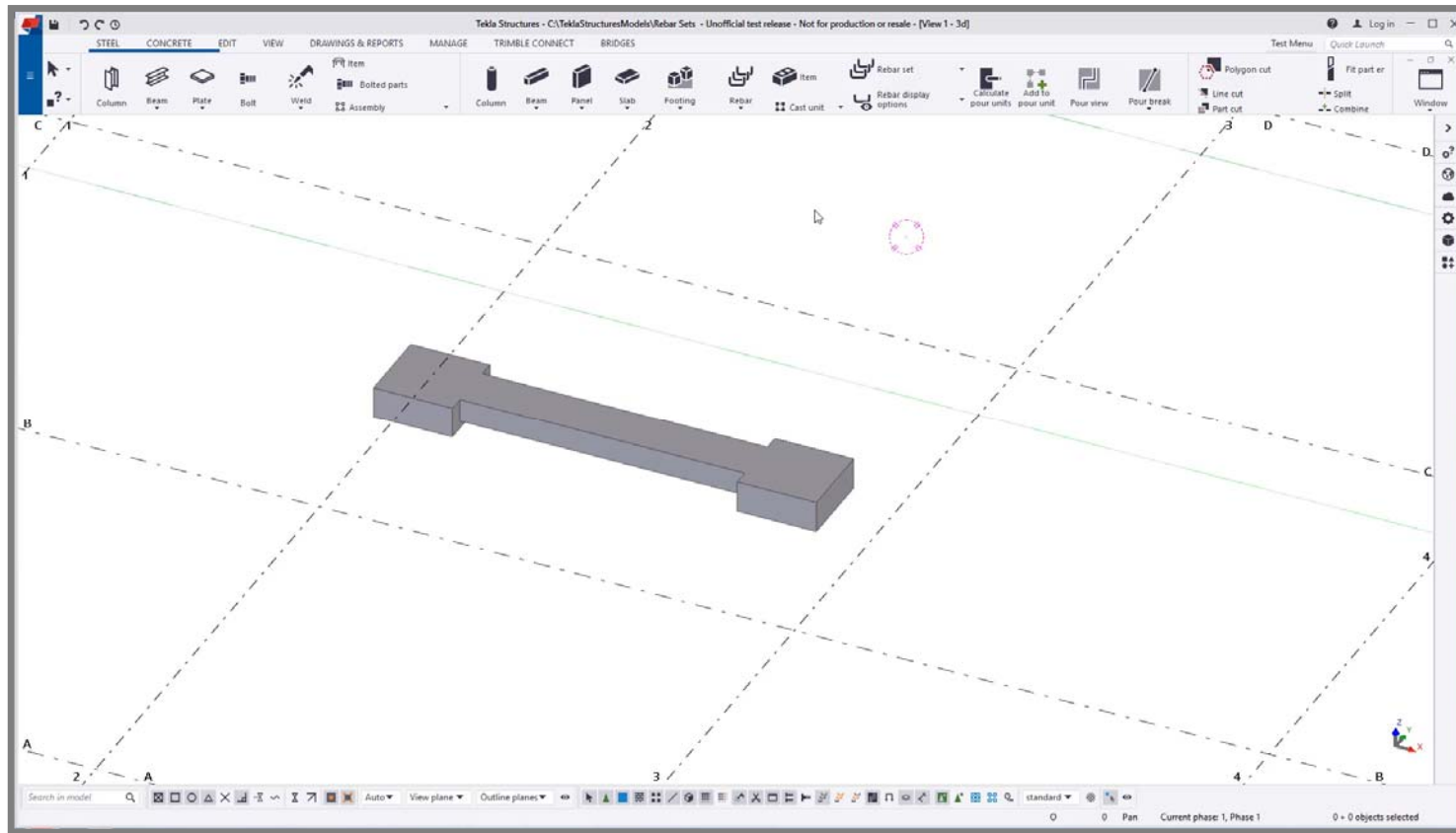

Concrete and Reinforcement: Rebar Sets and Cuts

- Rebar sets automatically recognize the cuts in the concrete parts.
 - Works with:
 - Create Longitudinal Rebar
 - Create Crossing Rebar
 - Create Planar Rebar
 - No longer have to create separate cuts for new Rebar Sets.
 - Ability to separately modify or delete cuts of rebar sets and the cuts of concrete parts.

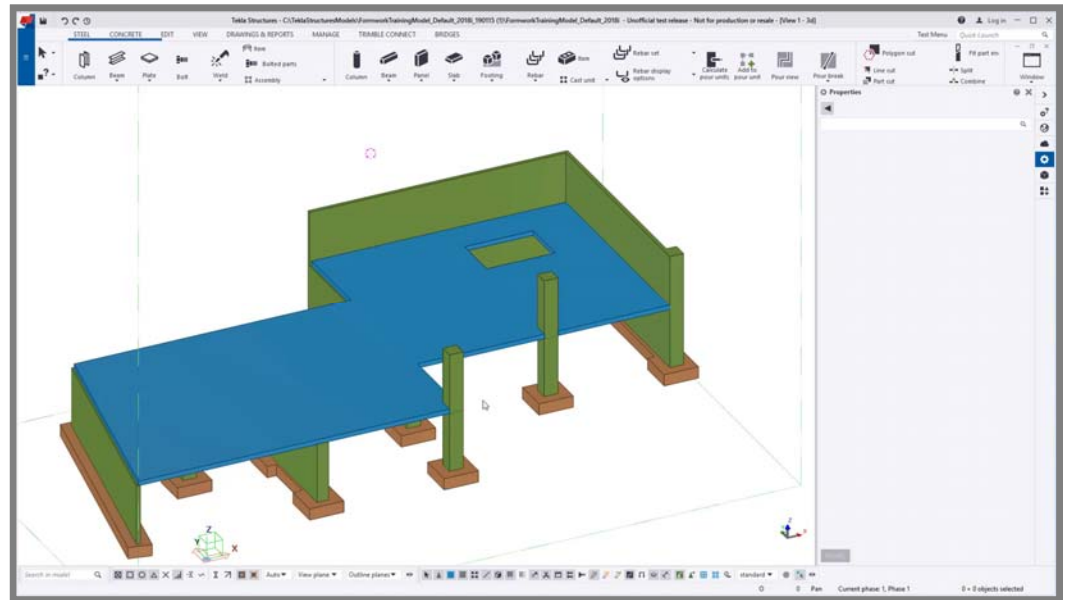

Concrete and Reinforcement: Rebar Sets at Inner Contours

- Can now create rebar set bars at the inner sides of cuts and hollow profiles.

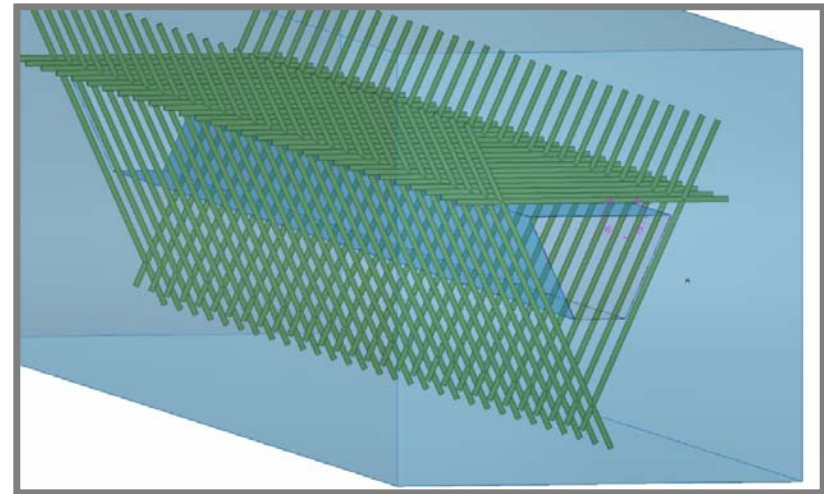

Concrete and Reinforcement: Rebar Sets at Inner Contours

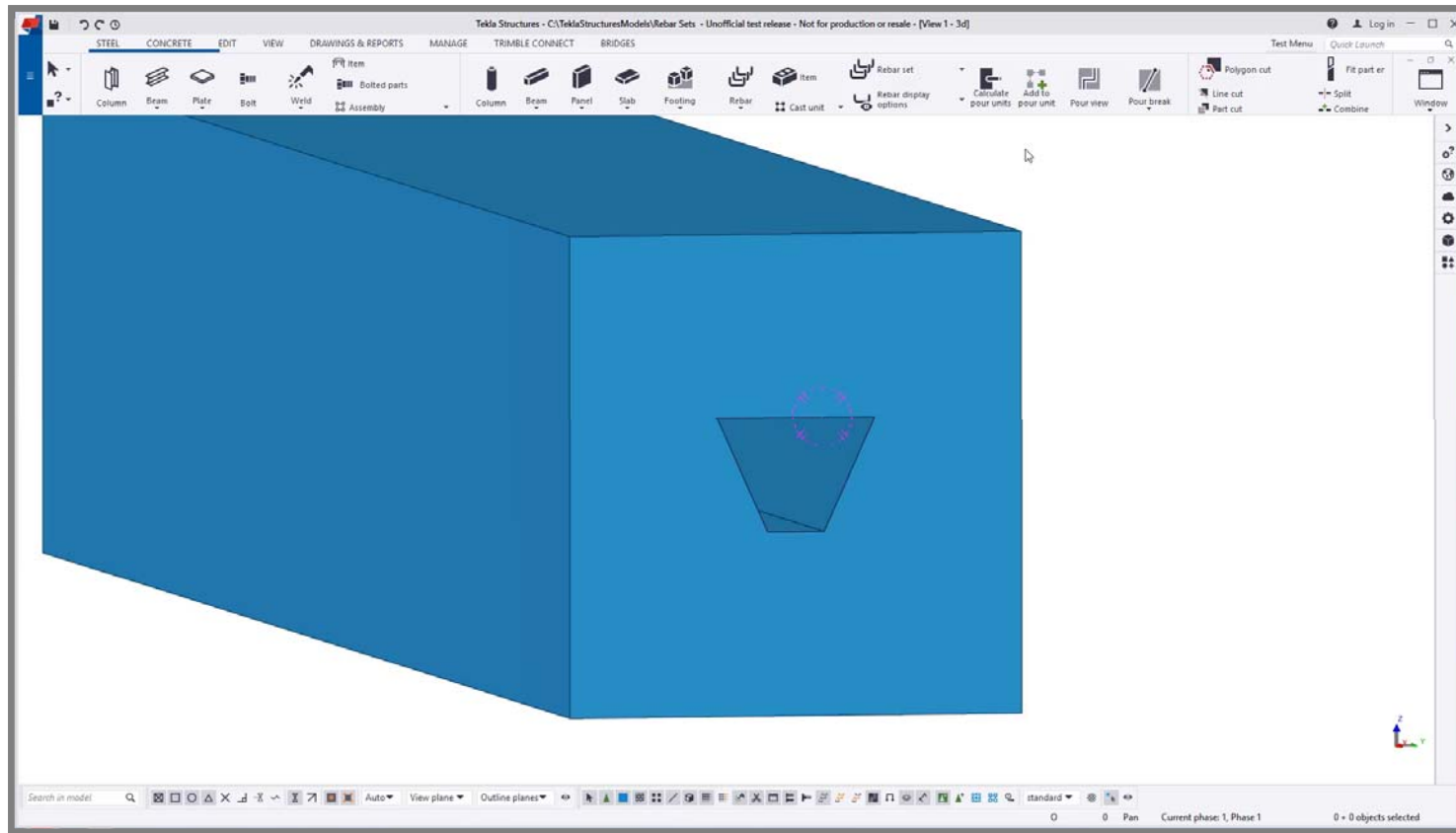

Concrete and Reinforcement: Rounding & Step Tapering

- Rounding for bars is implemented on Model, Set & Group level
 - Model level rounding is set in the options on the Rebar Set menu.
 - Set & Group level rounding is set in the properties pane of a Property Modifier.
- Values can be set to round up or down.
- Model level settings can be changed at any time but you must regenerate the sets for the new values to take effect.

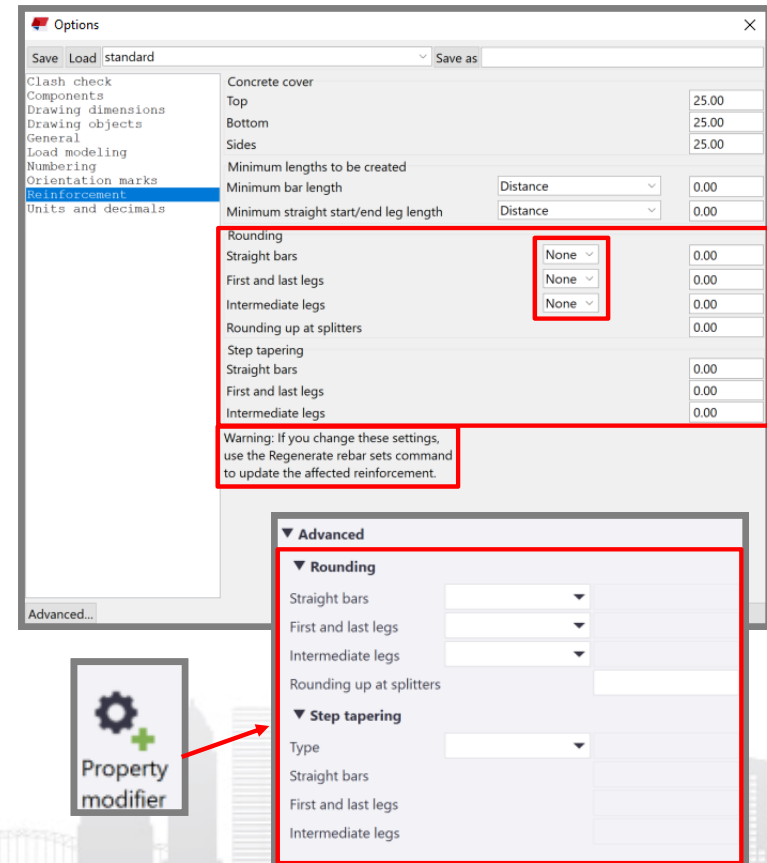

Concrete and Reinforcement: End Detail Improvements

- Hook Rotation

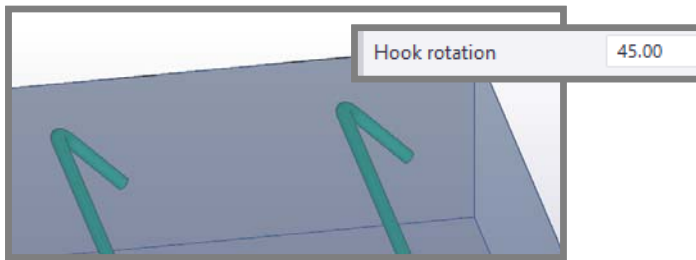

- Length Adjustment

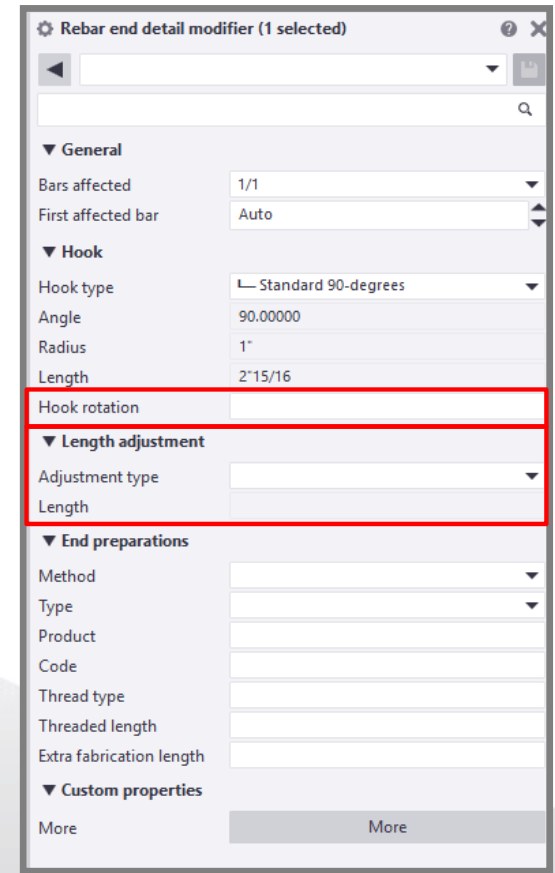
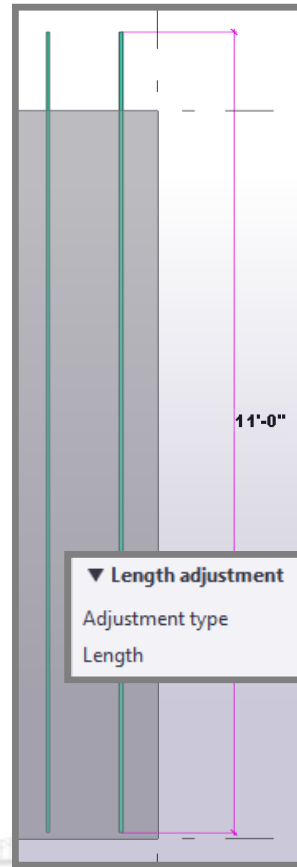
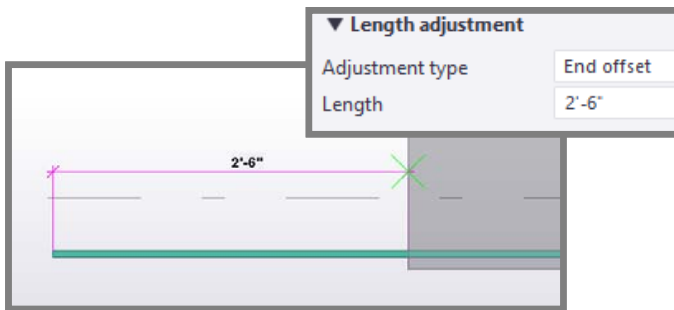

Concrete/Precast – Tekla Structures Pour Unit Workflow

Wednesday @ 10:00am

Here in Ballroom 4



What's New for Modeling

FORMWORK IMPROVEMENTS



Formwork: Easier to Control Items

- Formwork placing tools now automatically write UDA's on placed items.
- This enables for easier control for formwork items in model and drawings.
- Very useful for establishing drawing settings, selection/view filters or the Organizer.

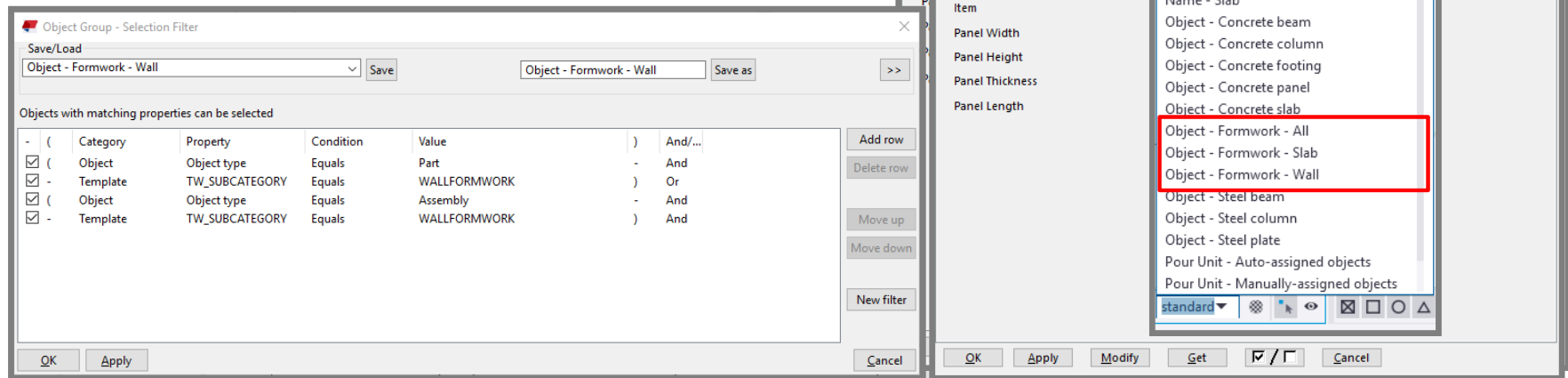

Formwork: Add Accessories Quickly

- It's now possible to use applied settings to automatically add accessories with one go.
- User can select which accessories to add.
- Can be used for several layouts or individual panels as well.

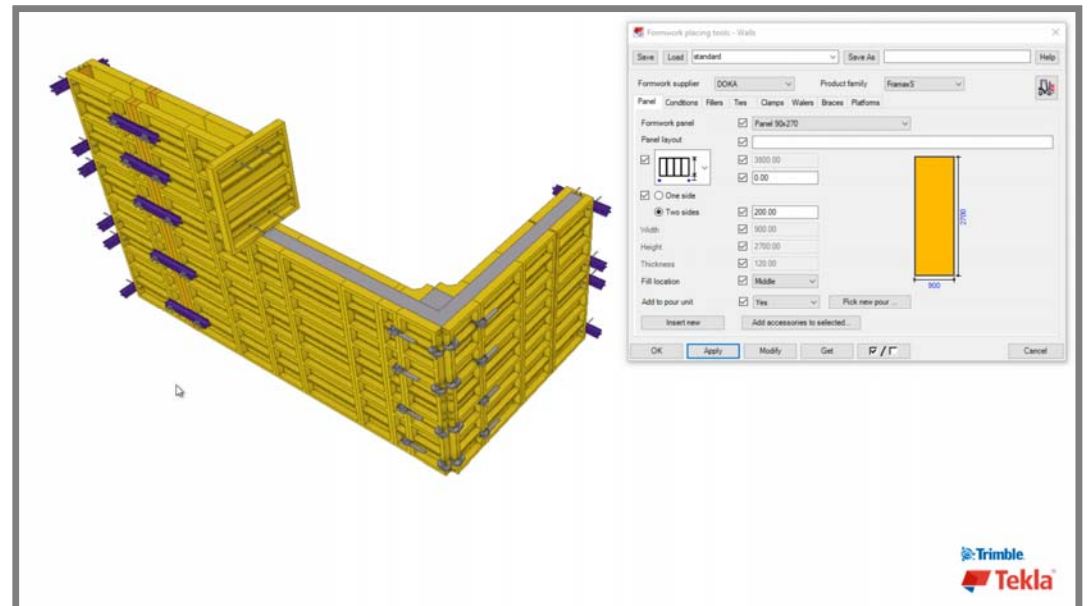

Formwork: Options for Ties

- It's now possible to have spacer between two panels along the tie.
- Spacer can be fixed or parametric.
- The spacers are configured with the file:
 - xxxx.Formworktools.TieSpacers.csv

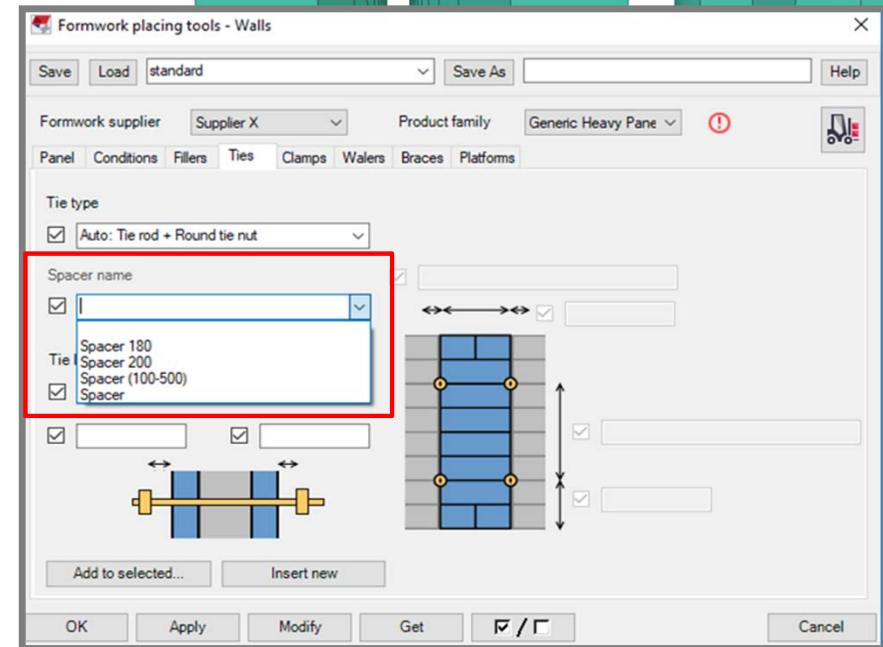

Formwork: Options for Ties

- The tie can now be extended over a waler.
- New fields to provide offset values for the front and back locks.
- These options are applied when applied and used with **A** **SELECTED...**

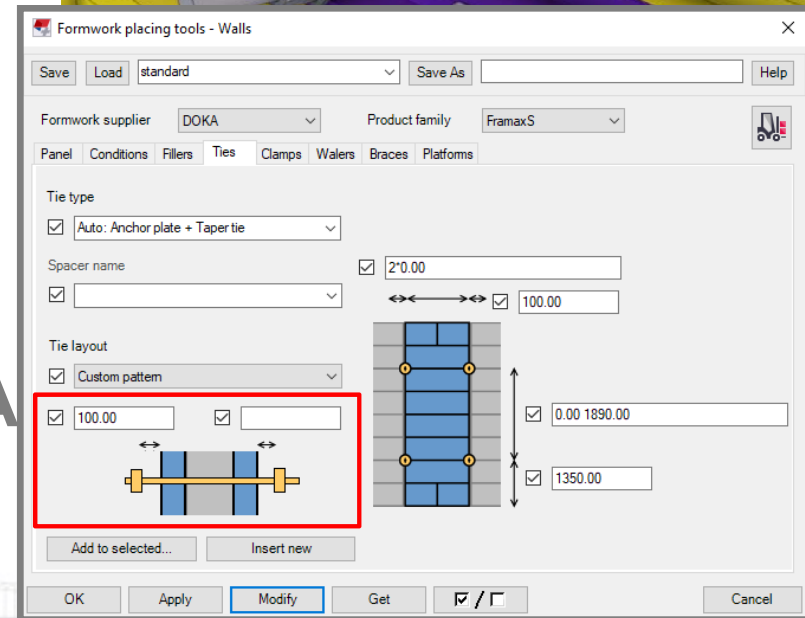
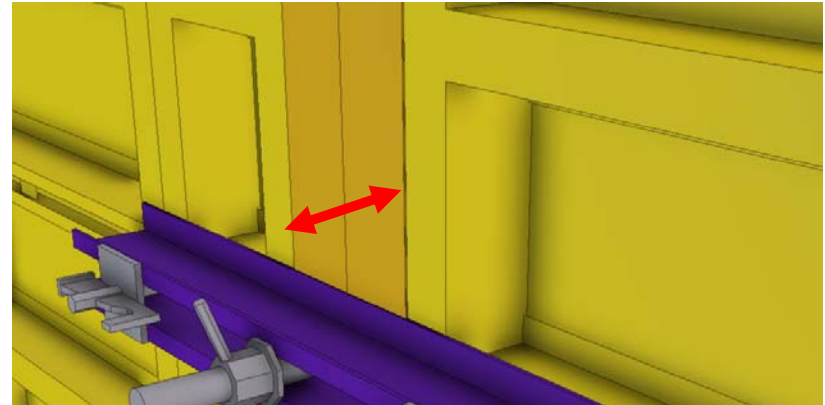

Formwork: Place Full Height Fillers Together with Clamps and Walers

- The fillers are now always placed in full height.
- The walers and the clamps can be added with the filler.
- Clamps have a new 'MaxFillerGap' parameter in `xxxx.FormworkTools.Clamps.csv` file

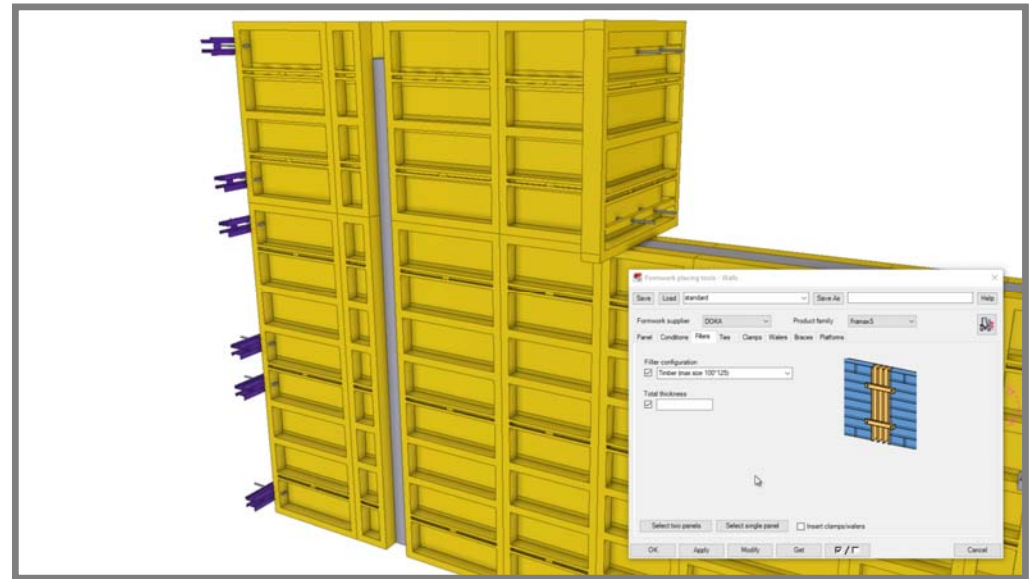

Formwork: Place Full Height Fillers Together with Clamps and Walers

- If the filler width is less than the preset parameter 'MaxFillerGap', clamps are inserted.
- The waler locations are preset by giving the following new parameters in the `xxxx.FormworkTools.Panels.csv` file.
 - WalerEdgeOffset
 - WalerX
 - WalerY

Formwork: More Adaptive Layouts

- Corner and panel sub-custom parts can be made parametric.
- Fillers are able to adapt to direct modification.

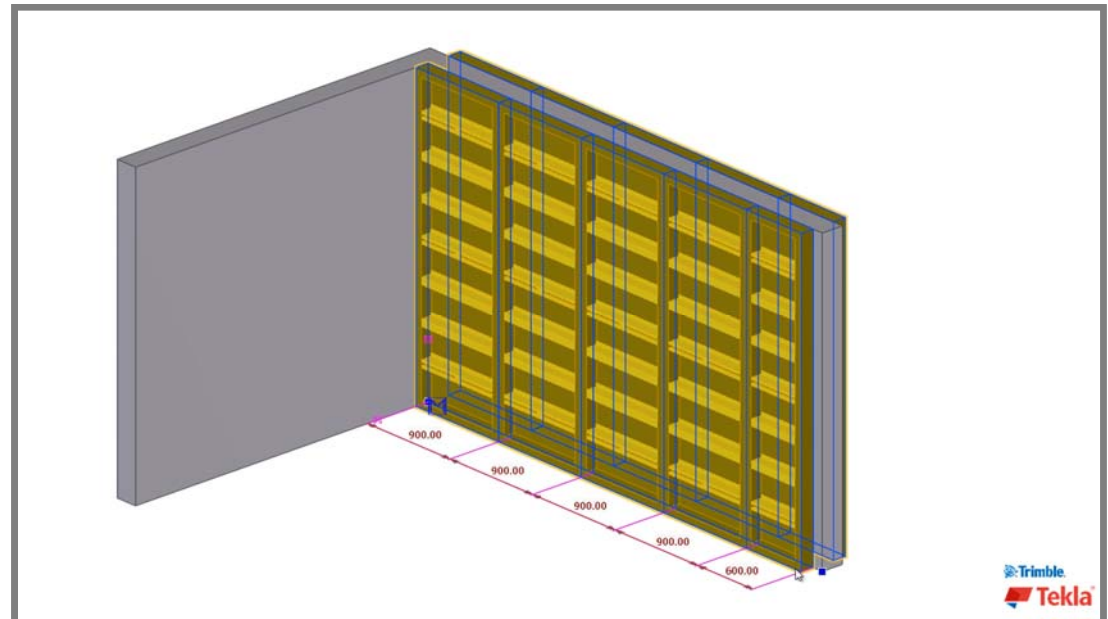

Formwork: Adding Fillers to Conditions

- Fillers can now be added anywhere.
- Additionally they can be automatically added to conditions.
 - **Limitation:** Only between two panels on the same surface.

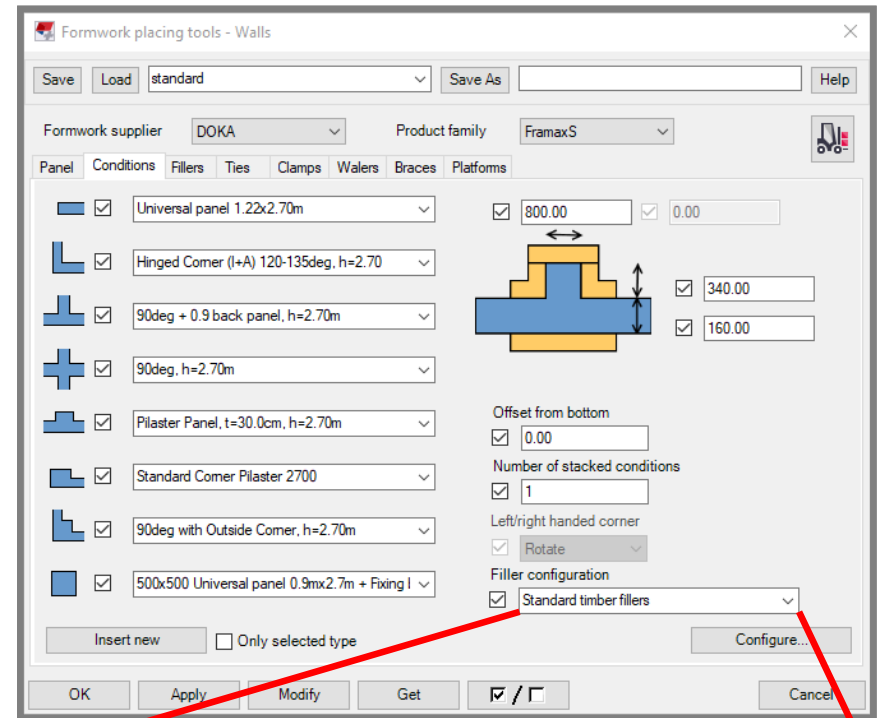

Filler configuration

- Standard timber fillers

Formwork: Add Girders and Shoring Quickly in One Go

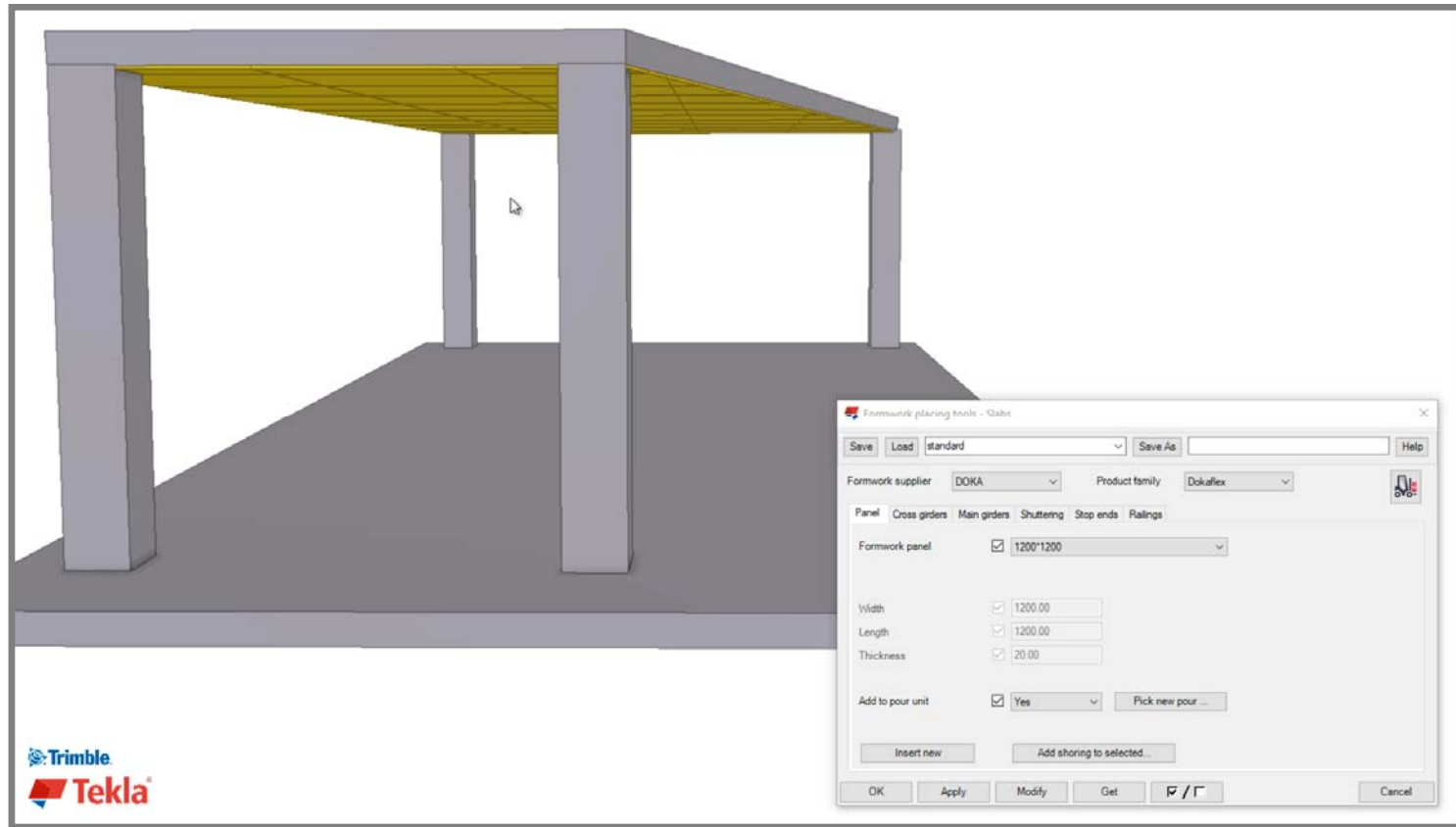

Formwork: Girder Overlap Adjustment Options

- User can now decide if and where girder overlap is adjusted.
- In these locations default overlap value is overridden.

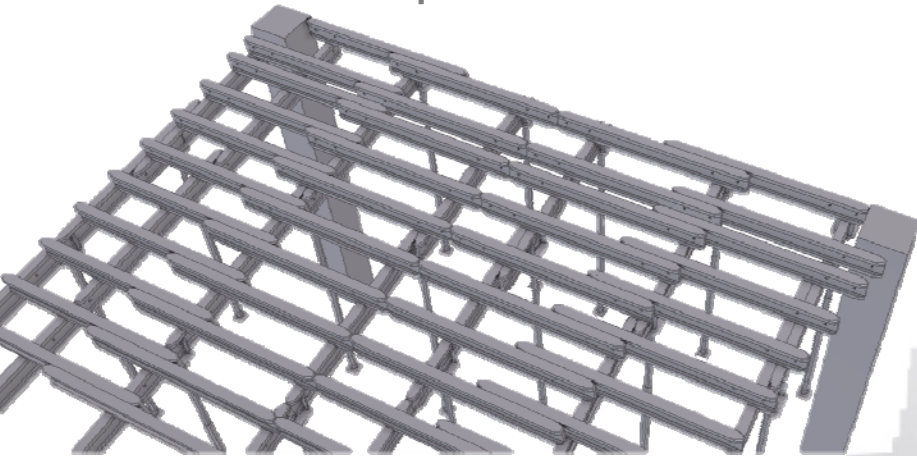

The screenshot shows the 'Formwork placing tools - Slabs' dialog box. The 'Formwork supplier' is set to 'DOKA' and the 'Product family' is 'Dokaflex'. The 'Panel' tab is selected, and the 'Girder name' is 'H20-1.8'. The 'Overlap' field is set to '0.00' and the 'Adjustment' dropdown is set to 'All'. The 'Adjustment' dropdown menu is open, showing options: 'All', 'First', 'Last', 'First and last', and 'None'. The 'Overlap' and 'Adjustment' fields are highlighted with red boxes.

Formwork placing tools - Slabs

Save Load standard Save As

Formwork supplier DOKA Product family Dokaflex

Panel Cross girders Main girders Shuttering Stop ends Railings

Girder name

H20-1.8

Overlap

0.00

Length(s)

Adjustment

All

All

First

Last

First and last

None

Add to selected... Insert new

OK Apply Modify Get /

Formwork: Double the Cross Girders in Panel Joints

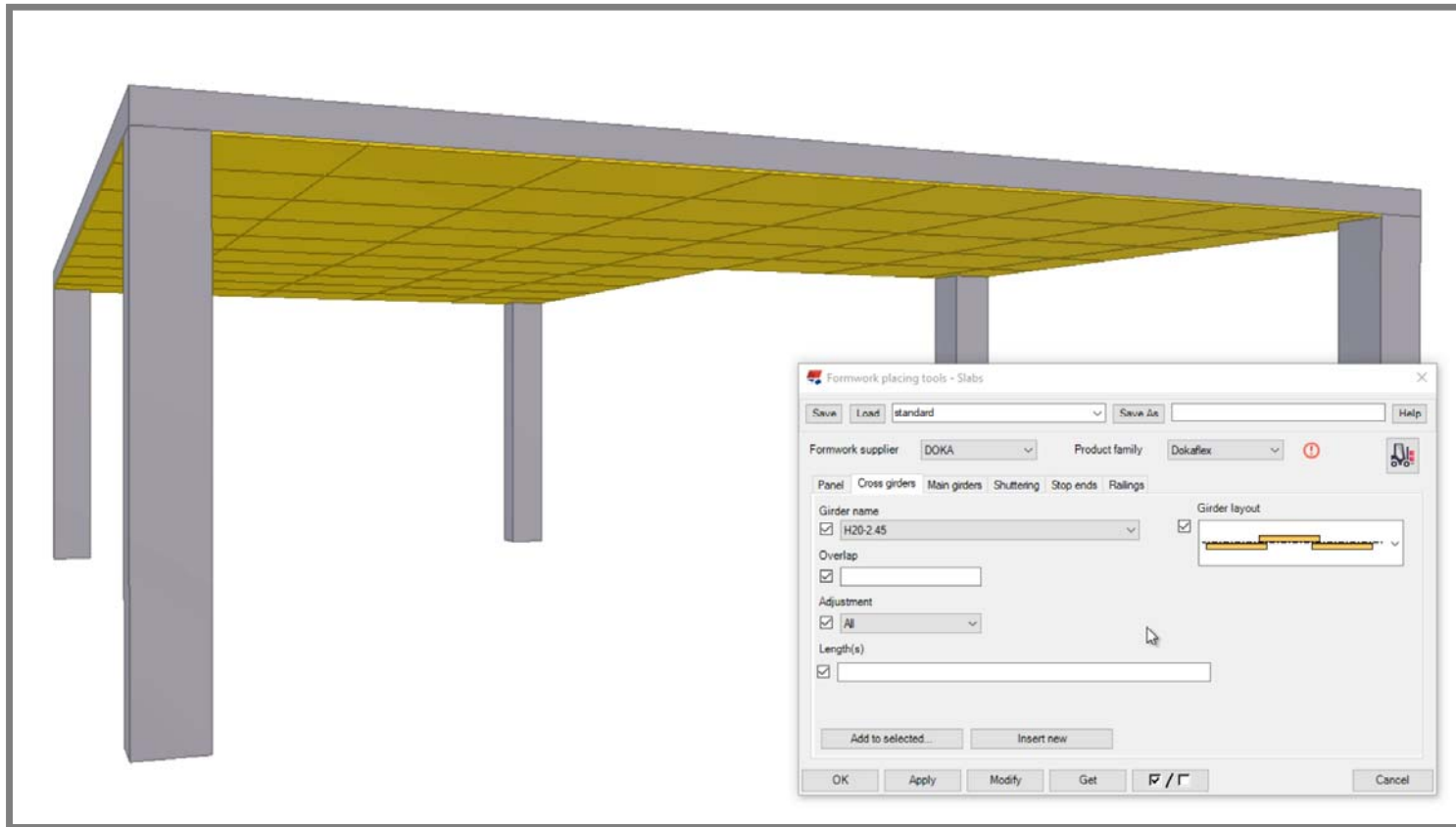

Formwork: Design Temporary Shorings for Any Structure

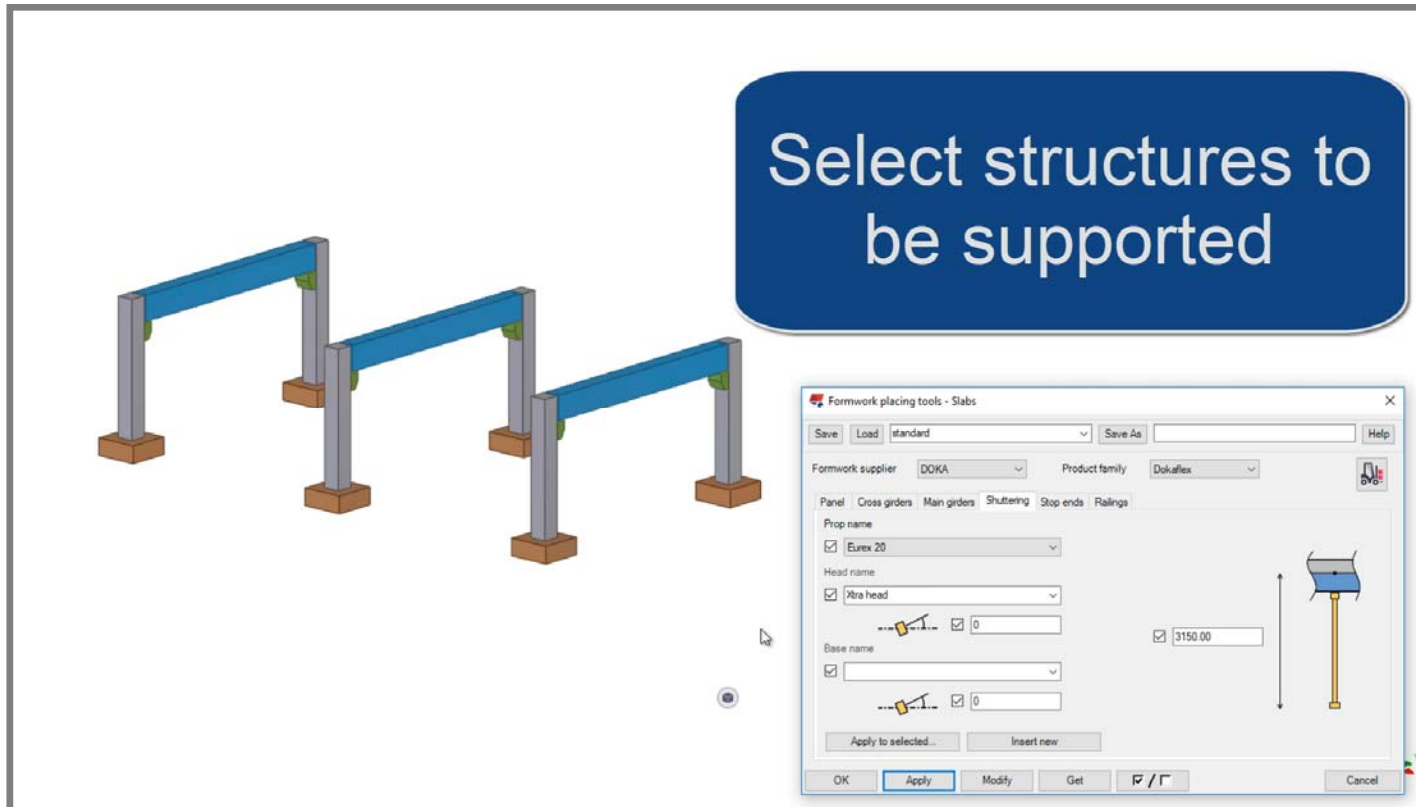

Concrete/Precast – Tekla Structures Formwork

Wednesday @ 4:00pm

Here in Ballroom 4



What's New for Modeling

HIGHLIGHTS IN COMPONENTS



Design-to-Cost Tool

- Cost as a design parameter.
- Calculates unit costs dynamically in the model.
 - Modeler can make more economical decisions.
 - Motivates to optimize!
- For all materials.
- Delivered as extension.
- Uses default currency for set in Windows Operating System.

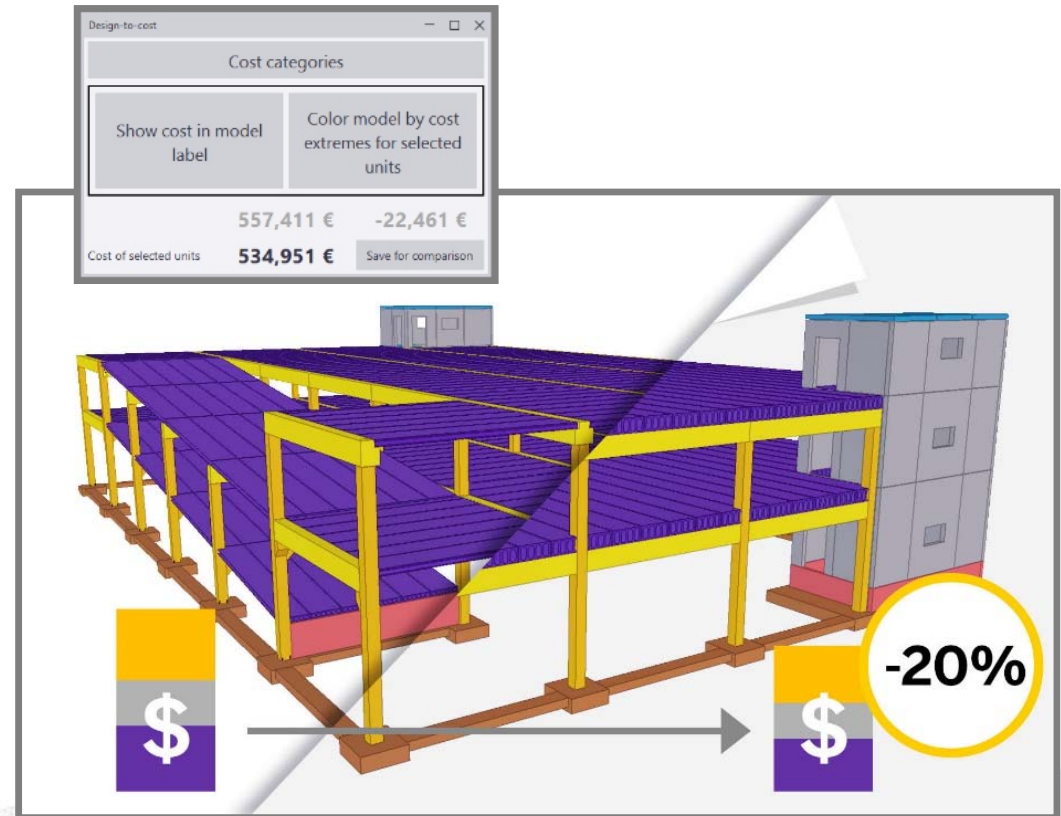

Design-to-Cost Tool

- Features:
 - Compare costs of alternative solutions.
 - Show cost in model label
 - Color selected group according to $\$/\text{yd}^3$.
 - Find relatively most expensive elements.
 - Cost as reportable object property.
 - Report, IFC property, model label, drawings, etc.

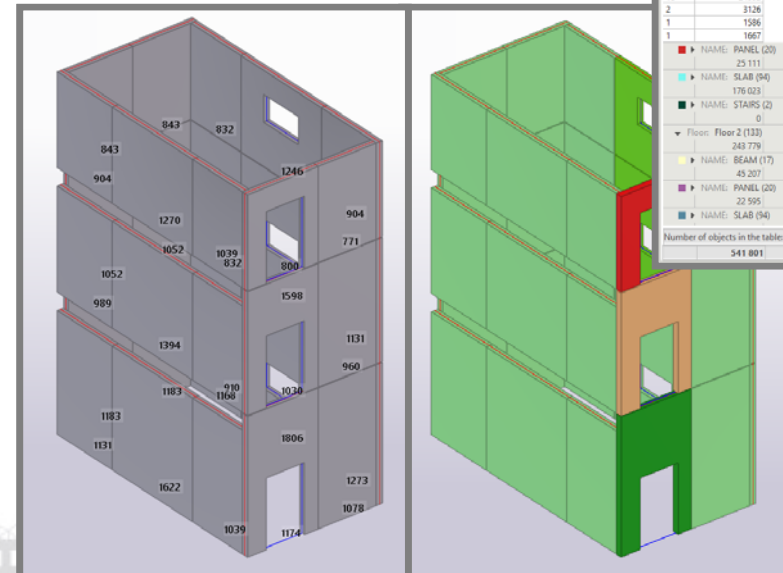
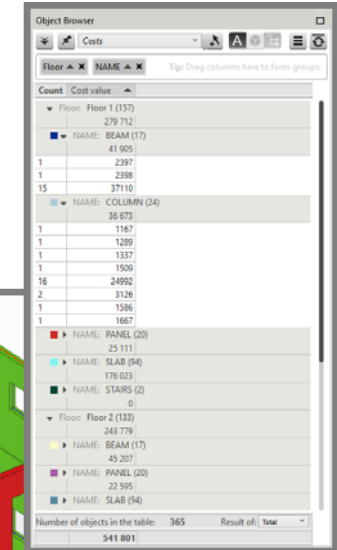

Design-to-Cost Tool

The screenshot shows the 'Design-to-cost definitions' window. The interface is divided into several sections:

- Category filter:** A red callout bubble points to the 'Solid wall' text in the 'Product name' field.
- Cost definitions category tree:** A red callout bubble points to the left-hand navigation pane, which shows a tree structure under 'Precast' > 'Area cost'.
- Cost element definitions:** A red callout bubble points to the right-hand panel, which contains fields for 'Cost name', 'Cost value', 'Quantity field', and 'Quantity unit'.
- Cost elements:** A red callout bubble points to the central table listing various cost elements and their values.

Area cost	Cost value	Quantity field	Quantity unit
Area cost	45.00 €	CUSTOM.WALL_GROSS_AREA	m2
Openings number	50.00 €		/Pcs
Openings area	7.00 €		/m2
Reinforcement	20.00 €		/m2
Lifters	20.00 €		/Pcs
Propping inserts	15.00 €		/m
Finishing	3.00 €		/m2
Transportation	0.10 €		/kg
Erection	45.00 €		/Pcs

Design-to-Cost Tool

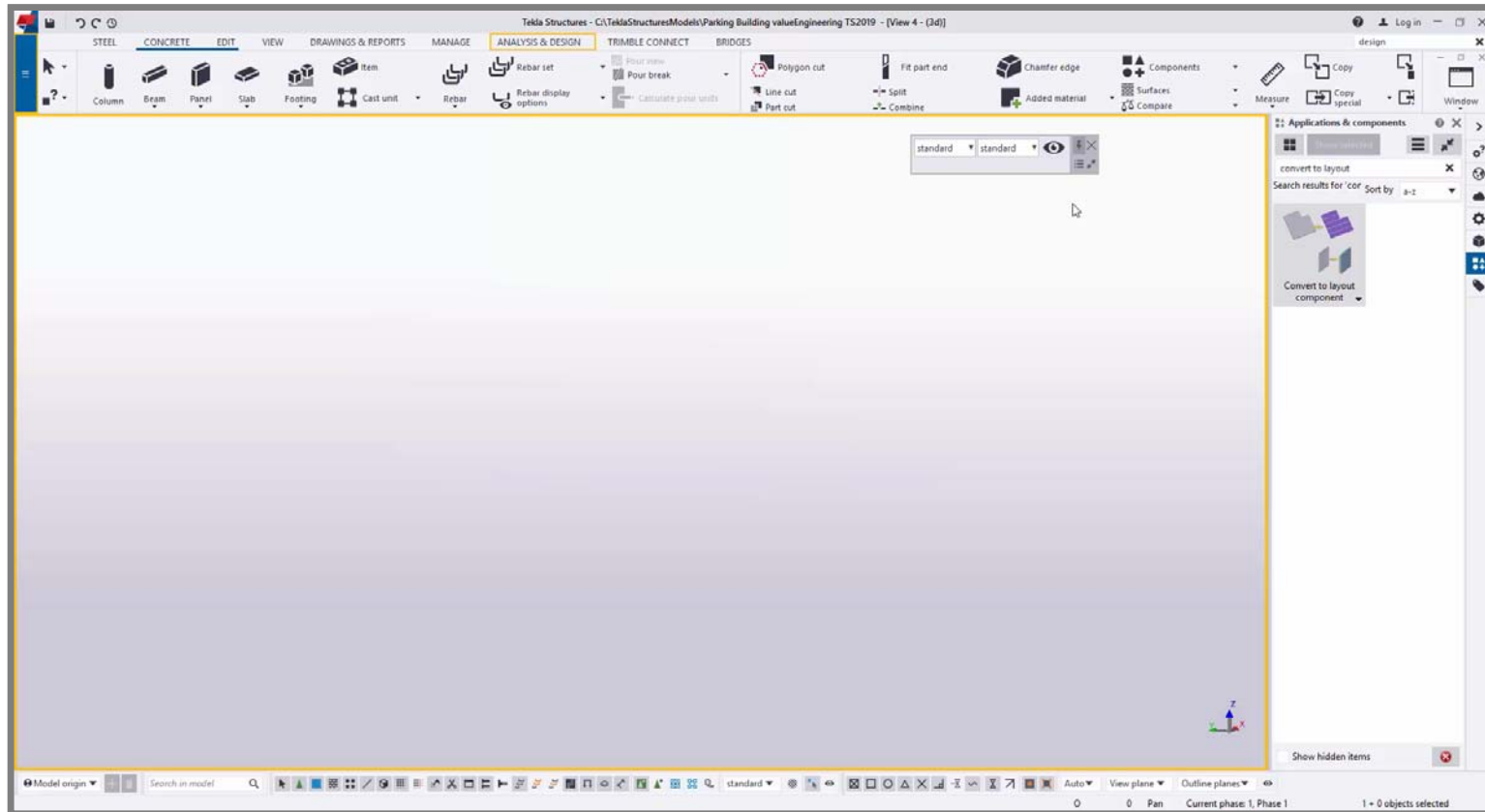

Double Wall Detail Enhancements

- Show the used values of definition files.
- UDA's written to panels for:
 - Reporting reinforcement area.
 - Cover thicknesses for reporting and avoid clashes with additional reinforcement.
 - Pallet rotation for automated drawing creation.

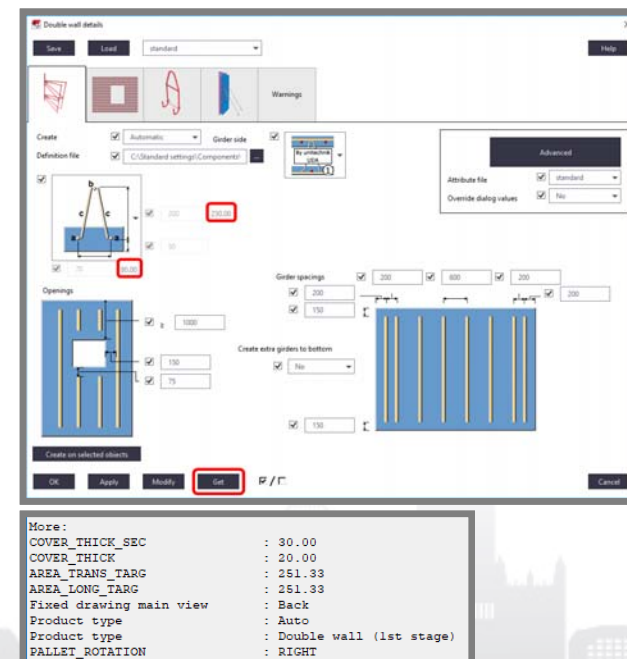

Half-slab reinforcement

- Versatile tool for detailing braced girders and reinforcement to half-slabs.

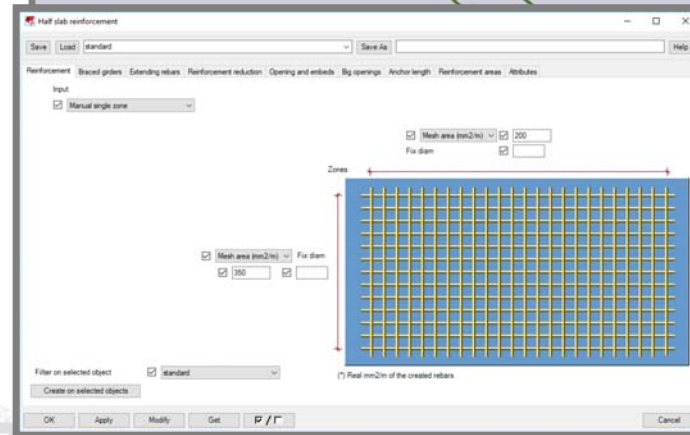
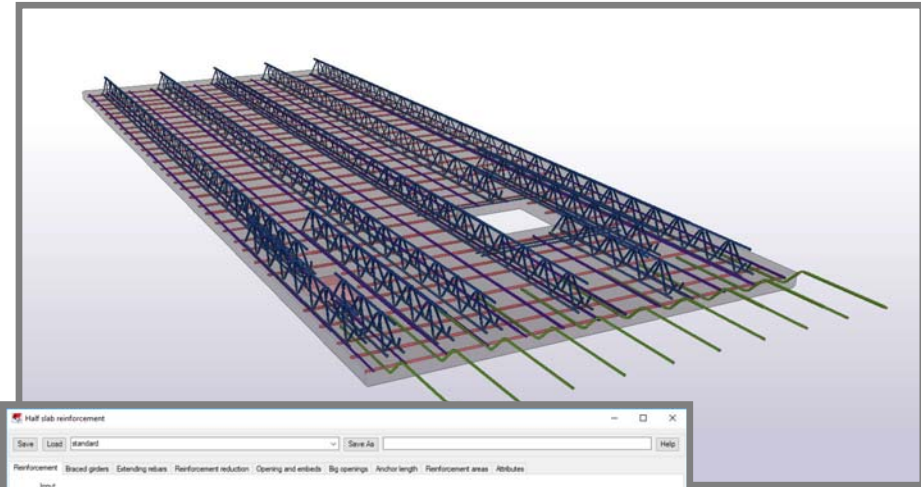
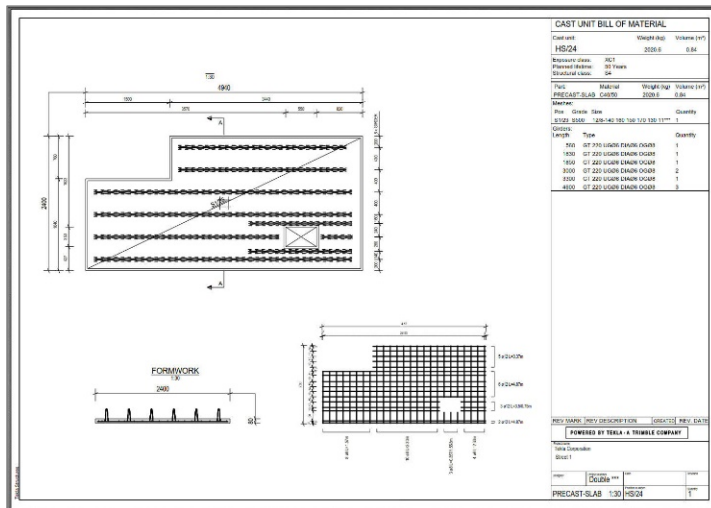

Half-slab reinforcement

- Optimization of reinforcement.
 - Input as required area

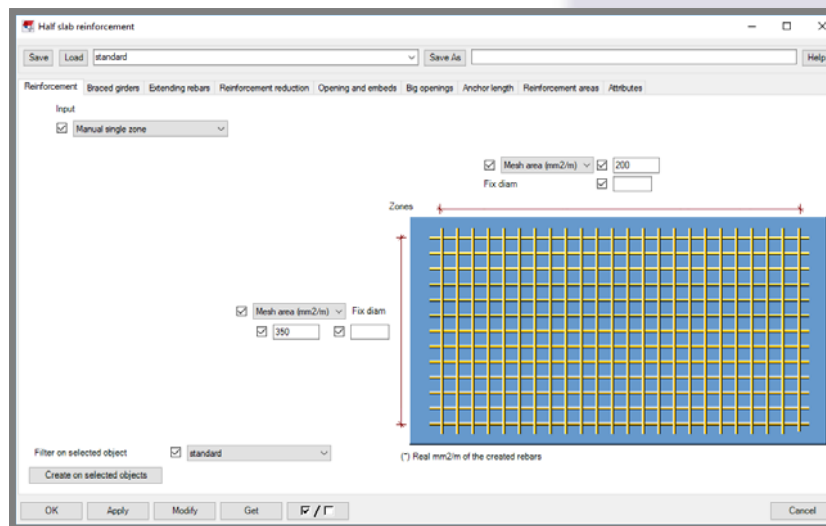
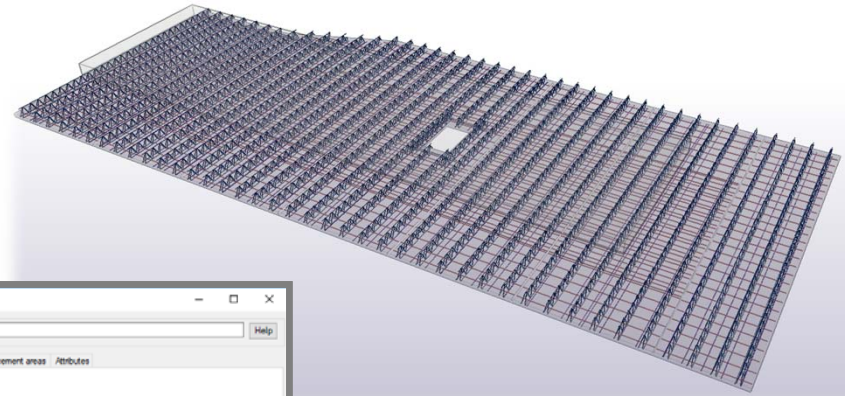

Half-slab reinforcement

- Optimization of reinforcement.
 - Input as required area
 - Available rebar sizes & lengths

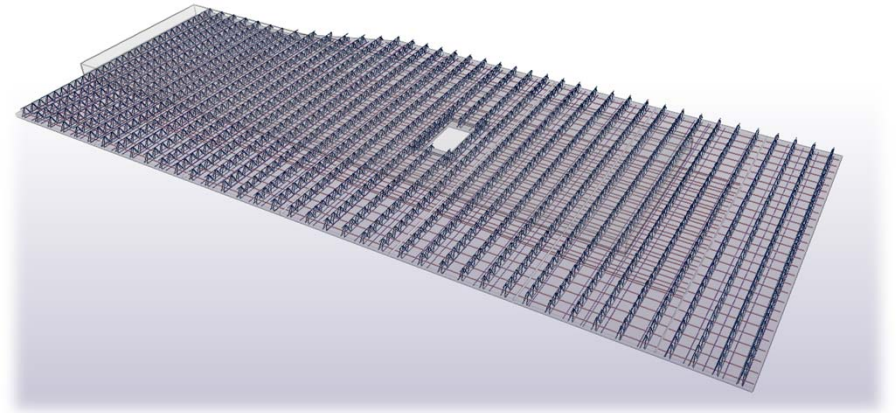

	Longitudinal		Transversal	
Available diameters	<input checked="" type="checkbox"/> 8 10 12	<input checked="" type="checkbox"/> Minimum number of rebars	<input checked="" type="checkbox"/> 6 8 10 12	
Max. number of consecutive diam.	<input checked="" type="checkbox"/>		<input checked="" type="checkbox"/>	
Rebar length	<input checked="" type="checkbox"/> Minimum 200.00	<input checked="" type="checkbox"/> Maximum 12000.00	<input checked="" type="checkbox"/> Minimum 200.00	<input checked="" type="checkbox"/> Maximum 12000.00
Mesh dimension	<input checked="" type="checkbox"/> 200.00	<input checked="" type="checkbox"/> 12000.00	<input checked="" type="checkbox"/> 200.00	<input checked="" type="checkbox"/> 12000.00
Min number of welding points	<input checked="" type="checkbox"/> Normal 3	<input checked="" type="checkbox"/> Extended 0	<input checked="" type="checkbox"/> Normal 3	

Half-slab reinforcement

- Optimization of reinforcement.
 - Input as required area
 - Available rebar sizes & lengths
 - Mesh welding/placement constrains

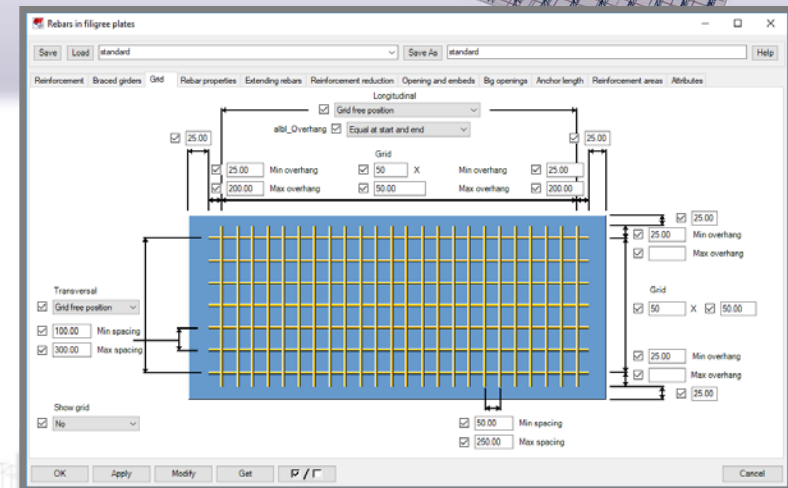
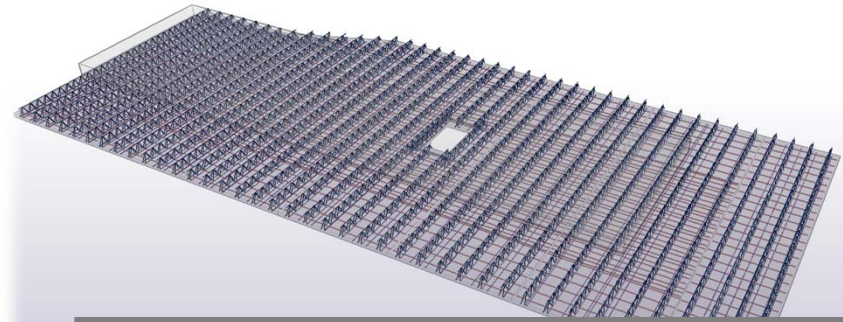

Half-slab reinforcement

- Optimization of reinforcement
 - Input as required area
 - Available rebar sizes & lengths
 - Mesh welding/placement constrains
 - Requirement areas

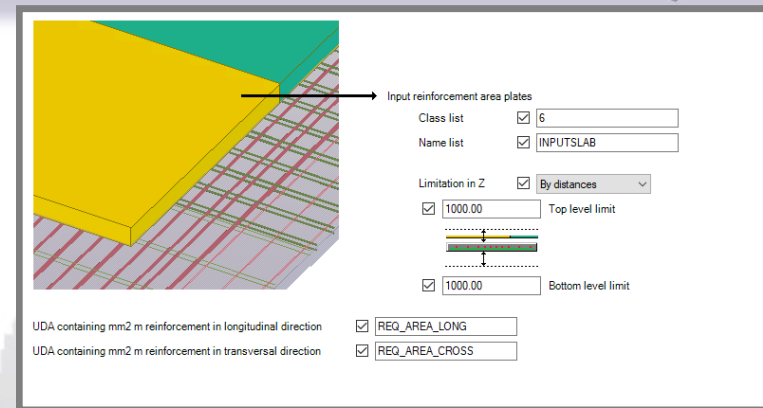
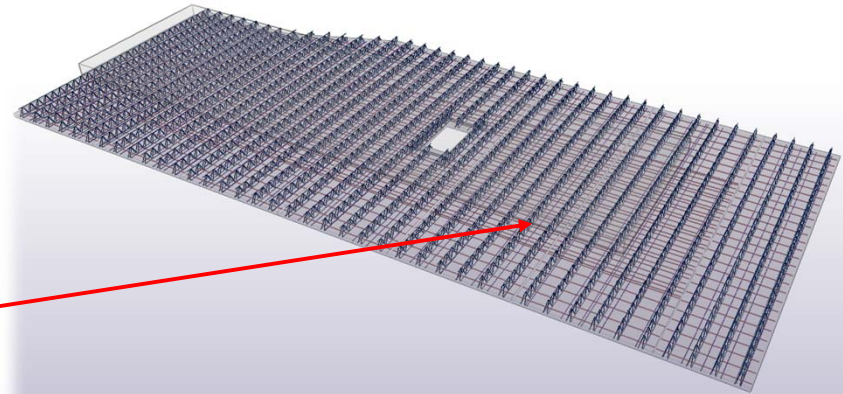

Half-slab reinforcement

- Optimization of reinforcement.
 - Input as required area
 - Available rebar sizes & lengths
 - Mesh welding/placement constrains
 - Requirement areas
 - Additional rebar (cuts & embeds)

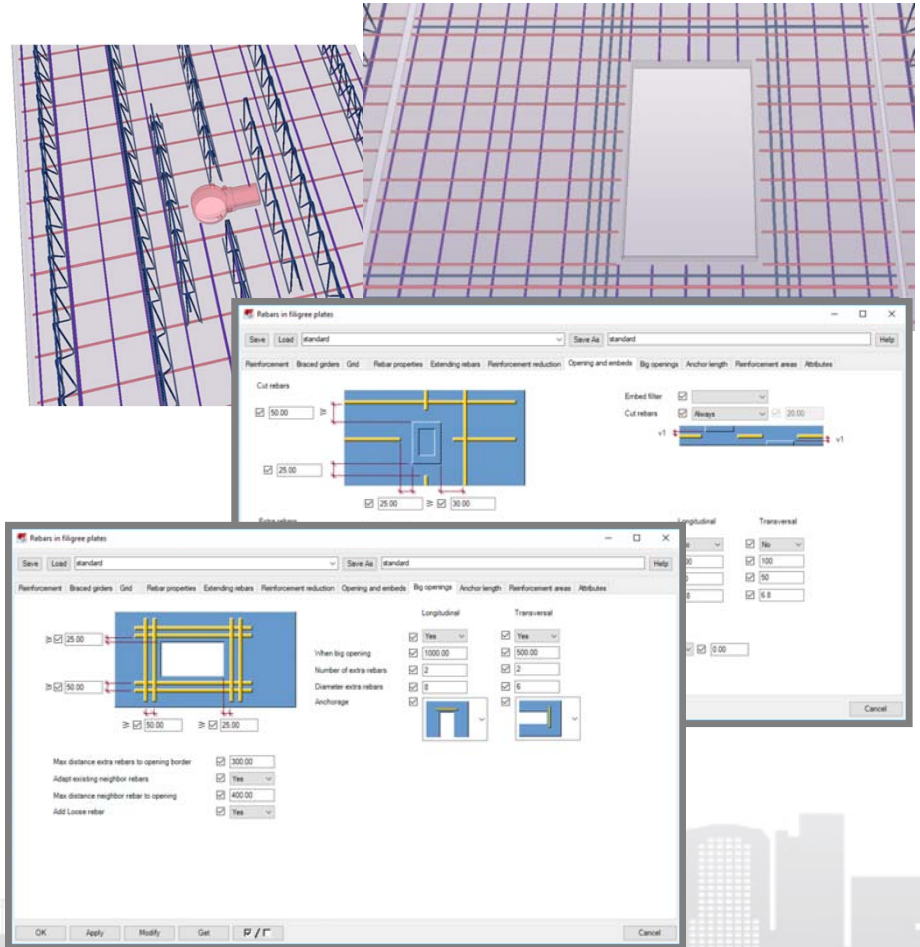

Half-slab reinforcement

- Optimization of reinforcement.
 - Input as required area
 - Available rebar sizes & lengths
 - Mesh welding/placement constrains
 - Requirement areas
 - Additional rebar (cuts & embeds)
 - Reinforcement reduction

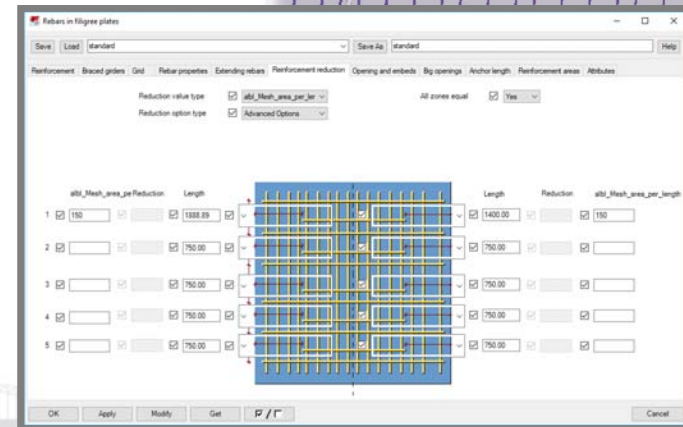
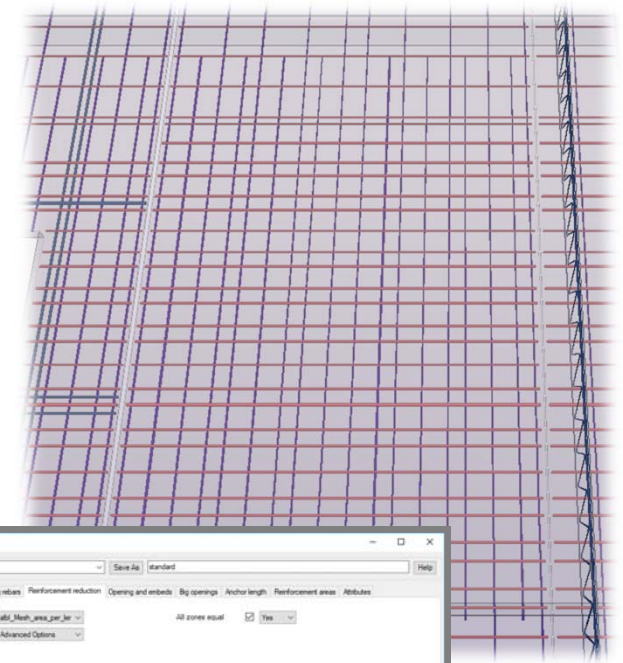

Half-slab reinforcement

- Optimization of reinforcement.
 - Input as required area
 - Available rebar sizes & lengths
 - Mesh welding/placement constrains
 - Requirement areas
 - Additional rebars (cuts & embeds)
 - Reinforcement reduction
 - Extended rebars

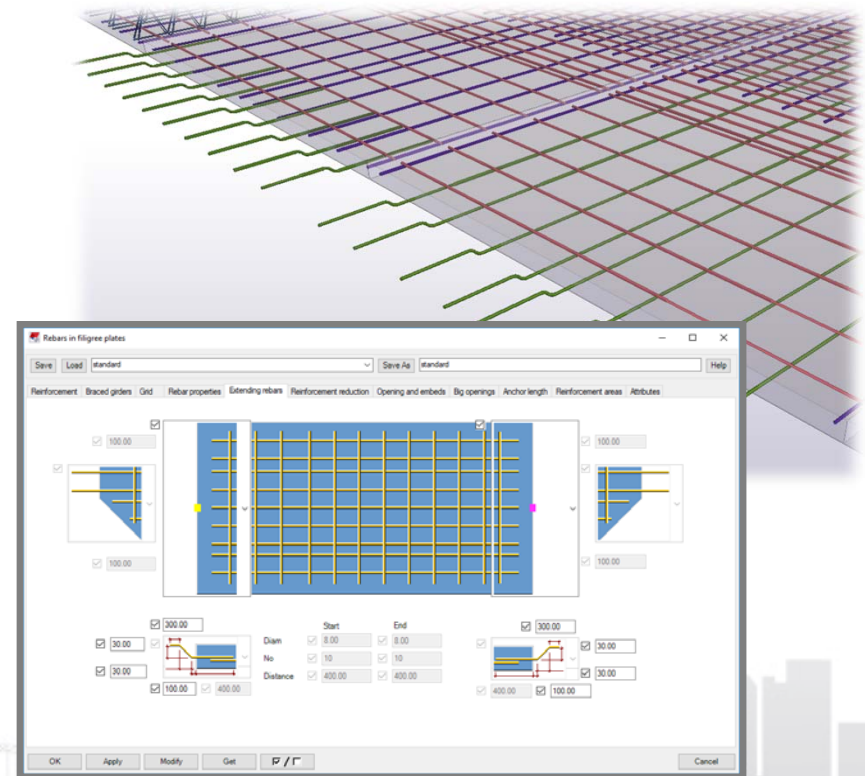

Half-slab reinforcement

- Braced Girders
 - Automatic type
 - Type from dropdown
 - Various placing options
 - Free spacing
 - Exact spacing
 - Grid placement
 - Extra Girders

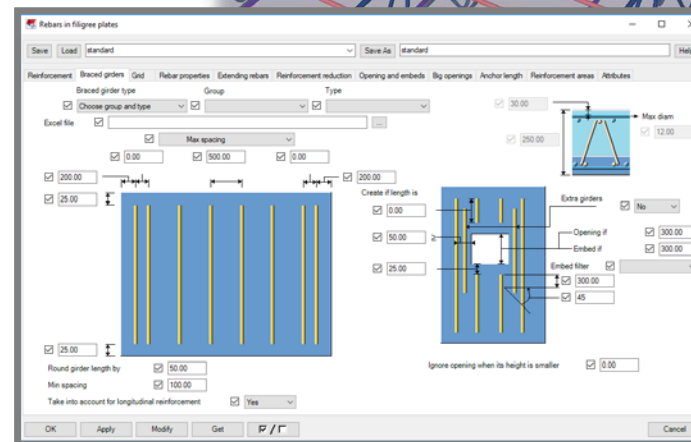
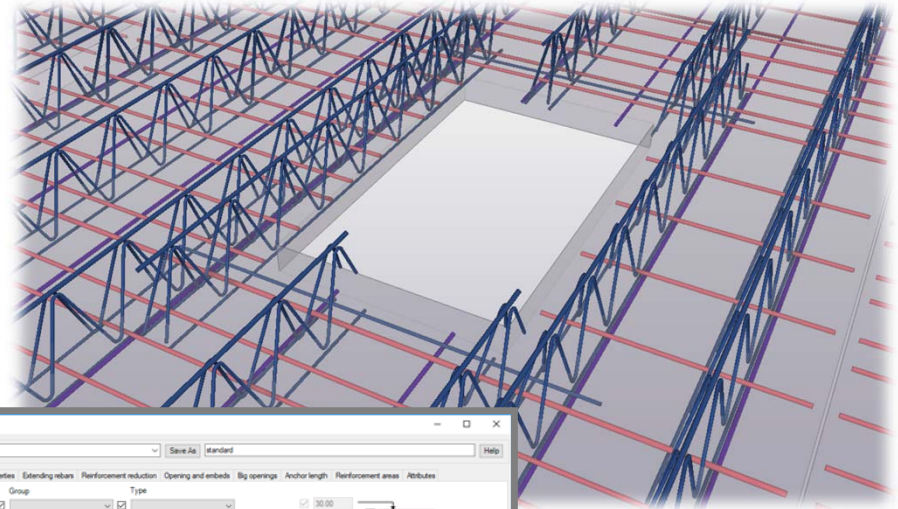

Wall to wall connection

- New options for wall connections.
 - Possibility to create wall thickening
 - New edge shape
 - Possibility to create edge shape as part object

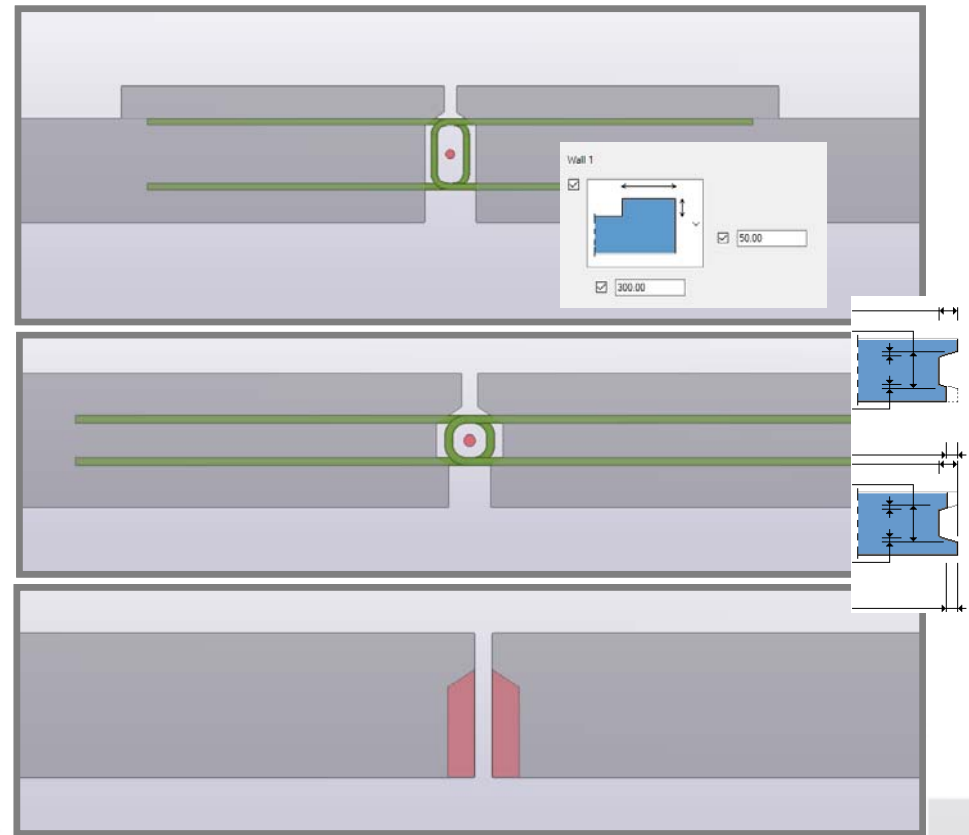
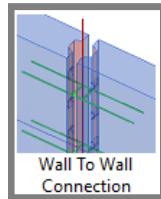

What's New for Modeling

UPDATES TO CMU TOOLS



New Tool: Shape Cleaner

- Previously some imported shapes caused missing faces or edges for items in drawings.
- New Tool: Shape Cleaner.
 - Investigates and corrects shape geometry.
 - Tries to create solid objects for non-solids.
 - Can create backups of shape geometry and revert to original if results are undesirable.
 - Use with shapes that have been imported to Tekla Structures models prior to version 2018i.

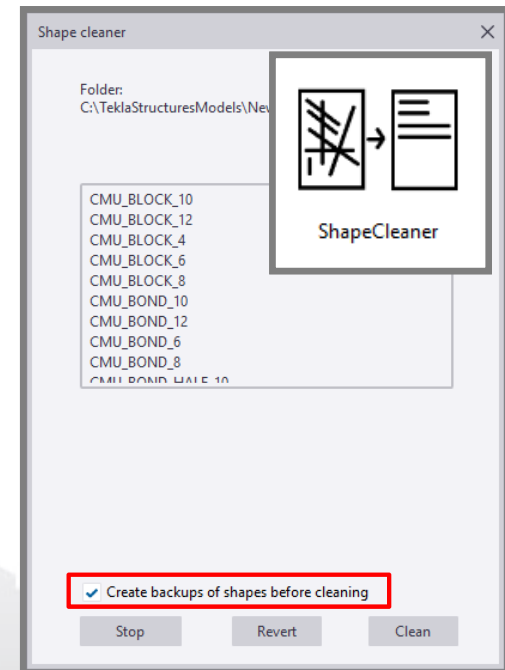

Updates to CMU Tools

- **NEW:** CMU Walls Swap Handles

- Flips the orientation in the case they were not modeled correctly so they can be aligned in a clockwise fashion quickly.

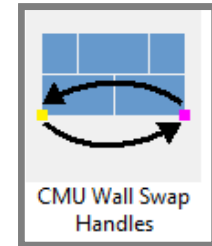

- **NEW:** CMU Corner Connection

- Makes edits to both walls at ends fit together without having to open or use the dialogs

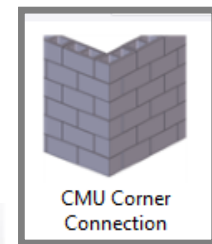

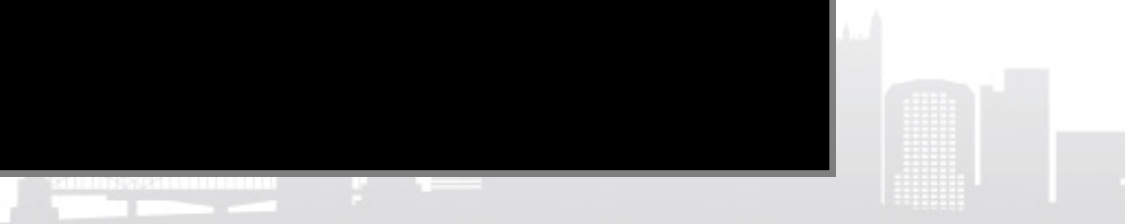

Updates to CMU Tools

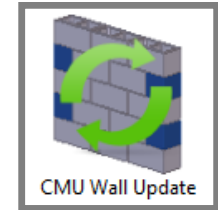

- **NEW:** CMU Walls Update Macro

- Used for existing models to take into use changes and improvements for new version all at once.

- **NEW:** CMU Drawing Creator

- Create drawings of selected walls.
- Select multiple walls and define max view length, this tool will then create multiple views to a new GA drawing of walls with proper view extrema and settings pre-loaded.

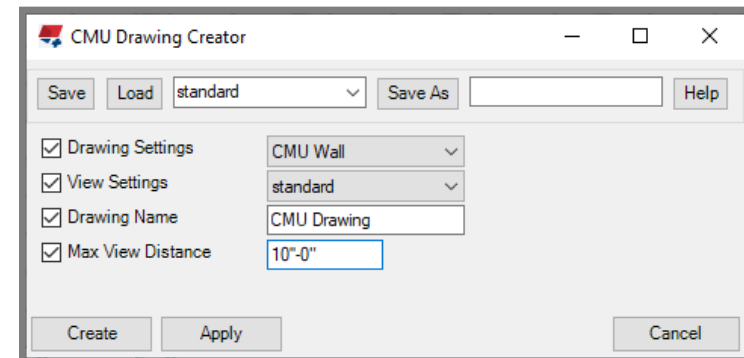

Updates to CMU Tools

- Split dogleg of vertical reinforcement to be new separate bar that can be turned on/off and flipped orientation.
- Added option to have two vertical bars per location in each orientation.
- Added new feature to tag blocks that have reinforcement going through them for both vertical and horizontal bars.
 - Allows for uniquely identifying blocks where grout would normally be used for reporting

What's New for Modeling

DRAWING IMPROVEMENTS



Drawings: Document Manager Improvements

The Drawing List is now The Document Manager

- Ability to create Manual Categories.
 - Add, Save or Remove new or existing documents.
 - Ability to Edit manual categories.
- Allows for better organization and workflow with drawings and documents.
 - Ability to organize by building, phase, status, elevation or other project needs.

Drawings: Document Manager Improvements

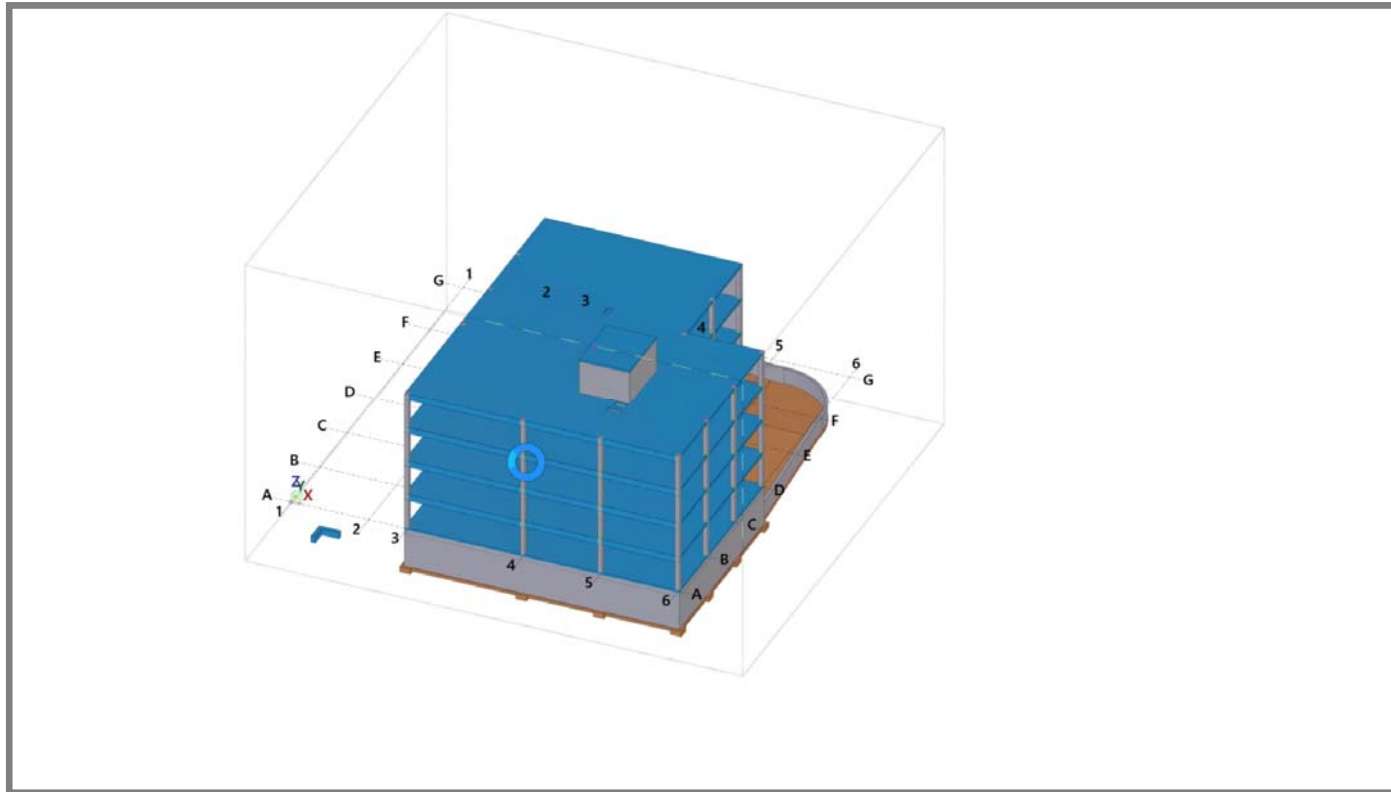

Drawings: Clone Selected in Drawings

NEW: Clone Selected in Drawings

- Available in General Arrangement Drawings.
 - Clones existing annotation objects, drawing object representations and styles from selected source objects to selected target objects.
- Recognizes:
 - dimensions, marks, texts, symbols, text files, and DWG/DXF files.
 - Sketch objects, such as circles, rectangles, and polygons.
 - Object representations & styles: line colors, line types, hatches.

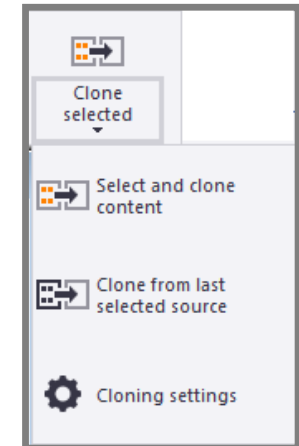

Drawings: Clone Selected in Drawings

- Configurable Settings:

- Merge
- Keep All
- Discard All
- Clone Building Object Properties and Styles
- Place Marks and Associative Notes according to Protection Settings.

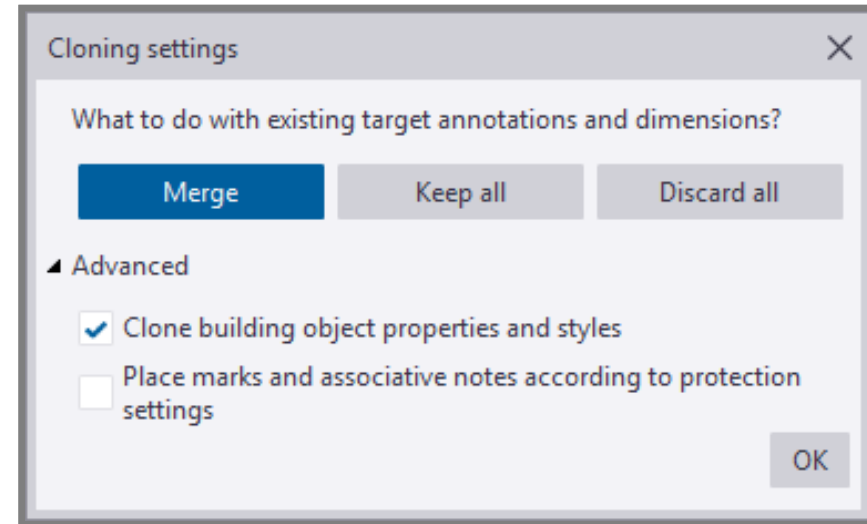

Drawings: Align Select Marks with a Point

- Align to a Point:

- New command to align selected marks.
- Avoids crossing leader lines.
- If Ortho mode is on, lines are placed at 0° , 90° , 180° or 270° angles.
 - Can hold down the middle mouse button during the command to change the angle of the marks.
- Simply select the marks and pick a point to align to.

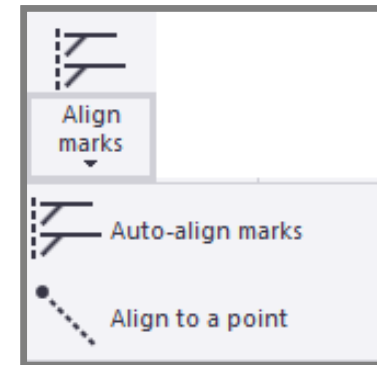

Drawings: Improvement Highlights

- New Options for Aligning View Labels
- Can now drag in the drawing.
 - Works with marks, dimensions or drawing objects.
 - Option in the Settings.
 - No longer have to select objects or grips.
 - Replaces Smart Select.

BEFORE

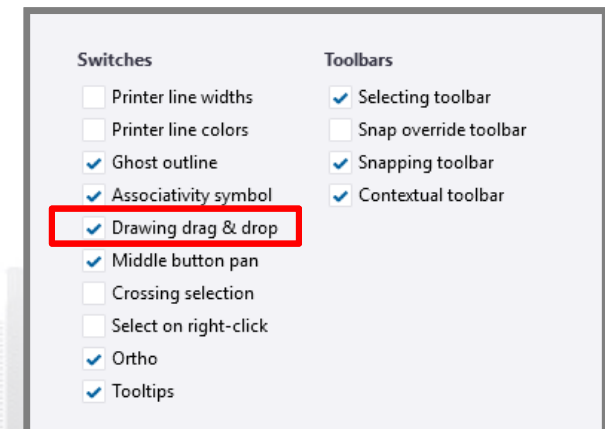
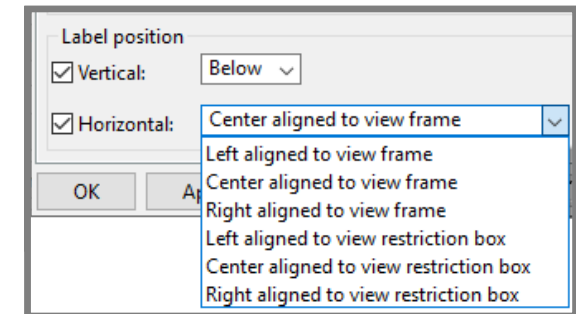

Drawings: Improvement Highlights

- Added **Zoom to Selected** in drawings.
- Changes in Snapshot Creation
 - No longer prompted to create when saving a drawing.
 - Controlled by Advanced Option.
 - XS_DRAWING_SHANPSHOT_CREATION
 - TRUE = Automatically creates snapshot
 - FALSE = Does not create snapshot

Drawings: Export Improvements

- Export Drawings to DWG/DXF dialog has been updated.
 - Layout is more user friendly and clear.
 - Preview Pane now opens as a separate window.
 - Exported block names not contain a drawing ID.
 - Allows for easier identification.
 - One dialog box for multiple drawings.
 - When using an Imperial Role, scale of geometry is kept accurate during exportation.

What's New for Modeling

INTEROPERABILITY IMPROVEMENTS



Trimble Connect

- Trimble Connect replaces Tekla Bimsight and Tekla Web Viewer by end of 2019.
 - Bimsight will no longer be supported but will remain available.
- Trimble Connector
 - Added ability to create new Trimble Connect Projects through Trimble Connector.
 - Eliminates the back and forth between Tekla Structures and Trimble Connect to get a project going for coordination.

Export to Revit Geometry

- New Application to export Native Tekla Objects to Revit.
 - Creates a Revit 2018 .rvt project file using a structural project template.
 - Can be exported with Model Origin, Work Plan or Base Points.
 - Exported family names as: **Part name-profile-grade-GUID**
 - Tekla Structures part attributes are exported and associated with the in-place family as family parameters.
 - Metric or imperial Revit project files are created based on the unit setting of the Tekla Structures model.

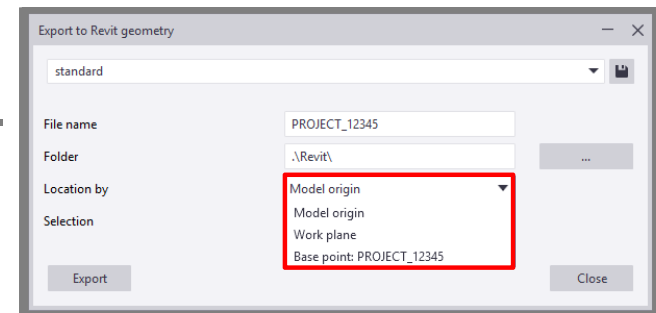

IFC Object Conversion

- Date now works when copying date type properties to UDAs that are defined as Date.
 - In IFC object conversion settings, the type needs to be set as integer.
- **Copy properties to UDAs** has been changed not to use reference object report functionality anymore.
 - This provides faster conversion and Date UDA usage as integer.

IFC Object Conversion

- The arc point calculation, chamfer combining, and the naming of the cut profiles have been improved.
- Fixed IFC object conversion previously did not handle or convert round cuts for plate



THANK YOU!



